



Heating Systems

OWNER'S MANUAL

CE-140 Multi-Oil Furnace
CE-180 Multi-Oil Furnace
CE-250 Multi-Oil Furnace
With CE-3 Burner

CE-330 Multi-Oil Furnace
CE-440 Multi-Oil Furnace
With CE-4 Burner

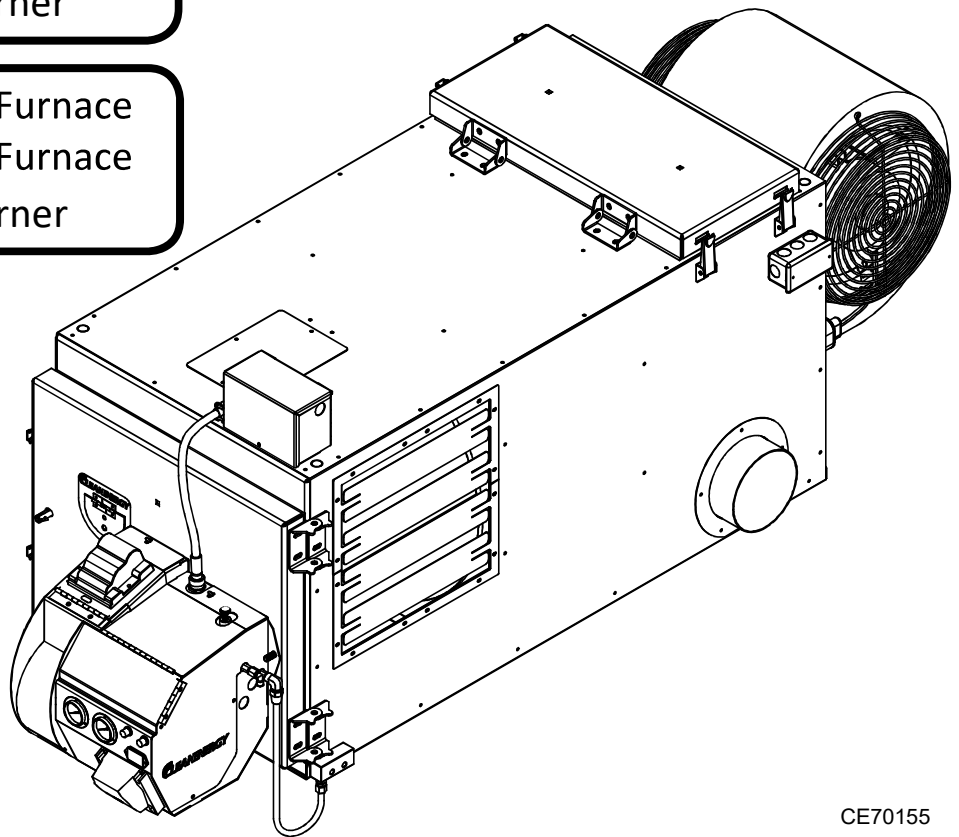

CE70155

633 N Helena St.
Spokane, WA 99202
(509) 535-1555
info@northstardirect.com



1210 N Oregon Ave.
Pasco, WA 99301
(509) 547-2323
info@northstarhotsy.com



WARNING: For your safety - DO NOT store gasoline or other flammable vapors and liquids in the vicinity of this or any appliance.

TRADEMARKS

The Clean Energy logo is a registered trademark of Clean Energy Heating Systems, LLC.

COPYRIGHT

Copyright © 2023 Clean Energy Heating Systems, LLC. This manual may not be reproduced or distributed without the prior written permission of:

Clean Energy Heating Systems, LLC.
PO Box 1341
479 Maple Street
Honey Brook, PA 19344

Subject to change without notice

TABLE OF CONTENTS

SAFETY CONSIDERATIONS AND GUIDELINES.....	4
TIPS FOR MAINTAINING HIGH PERFORMANCE.....	6
FURNACE ASSEMBLY.....	7
(1) Installing the blower.....	7
(2) Air discharge configuration.....	10
- Unit Heater (Free Air with no ductwork).....	10
- Central Furnace (ductwork installed).....	12
(3) Installing the combustion chamber target.....	13
(4) Installing the burner.....	13
(5) Installing the connector block and oil line.....	14
FURNACE INSTALLATION.....	15
(1) Selecting a location.....	16
(2) Mounting the furnace in position.....	17
(3) Connecting the electrical supply.....	18
(4) Installing the chimney components.....	19
(5) Oil storage tank set up	21
(6) Installing the metering pump and oil lines.....	21
(7) Connecting the compressed air line.....	26
(8) Installing the wall thermostat.....	27
PREPARING THE METERING PUMP FOR START UP.....	27
STARTING AND ADJUSTING THE BURNER.....	28
(1) Preparing the burner for start up.....	28
(2) Priming the oil pump.....	28
(3) Adjusting the Burner.....	28
RESETTING THE OIL PRIMARY CONTROL.....	29
SETTING THE DRAFT.....	30
MAINTENANCE.....	31
SEQUENCE OF OPERATION.....	35
TROUBLESHOOTING GUIDE.....	36
FURNACE DIMENSIONS.....	38
WIRE DIAGRAMS.....	41
BURNER POWER SWITCH.....	47
PARTS DIAGRAMS.....	48
CHIMNEY INSTALLATION DIAGRAMS.....	74
SERVICE RECORDS.....	76
WARRANTY INFORMATION.....	77

SAFETY CONSIDERATIONS AND GUIDELINES

HAZARD DEFINITIONS:

NOTICE: Intended to clarify or bring special attention to previous information.



CAUTION: Indicates a hazardous situation, which can result in minor or moderate personal injury if not avoided.



WARNING: Indicates a hazardous situation, which can result in death or serious personal injury if not avoided.



DANGER: Indicates a hazardous situation, which will result in death or serious personal injury if not avoided.

SAFETY CONSIDERATIONS:



WARNING: Incorrect installation, adjustment, or misuse of this heating equipment could result in death, severe personal injury, or substantial property damage.

To the Equipment Owner:

- Read and understand all instructions provided in this manual
- Installation and service must be completed by qualified personnel who are familiar with used oil-fired appliances.

To the Professional, Qualified Installer or Service Agency:

- Read and carefully follow all instructions provided in this manual before installing, starting, or servicing this heating equipment.
- All installations must be made in accordance with state and local codes having jurisdiction.



DANGER: DO NOT store or use gasoline or other flammable/explosive liquids/vapors in or around the furnace.



DANGER: DO NOT operate the furnace if excess oil, oil vapors, or fumes have accumulated in or around the furnace.



DANGER: Improper installation, operation, or maintenance of the furnace may create a fire or explosion hazard.



WARNING: DO NOT mix unapproved substances to the used oil supply, such as:

- Anti-Freeze
- Carburetor Cleaner
- Paint Thinner
- Parts Washer and/or Solvents
- Gasoline
- Oil Additives
- Chlorinated solvents
- Any other inappropriate / hazardous material

Instruct your personnel **NEVER** to add unapproved substances to your used oil.

Burning any unapproved substance will immediately **void the furnace warranty** and may cause damage and unsafe operating conditions.



WARNING: Unauthorized furnace modifications may cause damage and unsafe operating conditions.

SAFETY CONSIDERATIONS AND GUIDELINES



WARNING: The CE-3 Burner is only approved for use on the CE 140, CE 180 or CE 250 furnace. The CE-4 Burner is only approved for use on the CE 330 furnace. Likewise, furnaces manufactured by Clean Energy Heating Systems are only approved for use with burners manufactured by Clean Energy Heating Systems.



WARNING: The installation, operation, and maintenance of this equipment in the United States must be done by qualified personnel according to instructions in the Clean Energy Heating Systems Owner's Manual and in accordance with all national, state, and local codes or authorities having jurisdiction and the following standards:

NFPA 30	Flammable and Combustible Liquids Code
NFPA 30A	Automotive and Marine Service Station Code
NFPA 31	Installation of Oil Burning Equipment
NFPA 70	National Electrical Code
NFPA 88A	Parking Structures
NFPA 88B	Repair Garages
NFPA 211	Chimney's, Fireplaces, Vents and Solid Fuel Burning Appliances

Likewise, the installation, operation, and maintenance of this equipment in Canada must be done by qualified personnel according to instructions in the Clean Energy Heating Systems Owner's Manual and in accordance with all regulations and authorities having jurisdiction and the following CSA Standards:

B139	Oil Burning Equipment
B140	General Requirements for Oil Burning Equipment
C22.1	Canadian Electrical Code, Part 1

GUIDELINES FOR FURNACE USE:

- This furnace is for industrial and/or commercial use only. This furnace is not intended for residential use.
- This furnace is safety listed to burn the following fuels:
 - #2 fuel oil (Diesel Fuel) *
 - Used crankcase oil up to 50 SAE
 - Used hydraulic oil
 - Used automatic transmission fluid (U.S.)
- The EPA regulations for burning used oil are as follows:
 - Your supply of used oil is generated on-site. You may also collect oil from "do-it-yourself" oil changers.
 - Do not mix hazardous wastes, such as chlorinated solvents, with your used oil.
 - The exhaust gases of the furnace must be vented to the outside with an appropriate stack system.
 - The furnace is used to recycle used oil for "heat recovery". The furnace is not to be used in warm weather just to dispose of used oil.

* #2 Fuel Oil (Diesel Fuel) should be mixed with other used oil to increase the viscosity and allow proper fuel delivery.

Approved Method to
Dispose of Waste Oil



EPA United States
Environmental Protection
Agency

- Only trained authorized personnel should service and maintain the furnace. Be sure the furnace receives annual maintenance to ensure safe and efficient operation.

SAFETY CONSIDERATIONS AND GUIDELINES

GUIDELINES FOR USED OIL TANKS:



WARNING: To avoid serious injury or death, only store petroleum based substances in the oil supply tank (the following are approved fuels):

- (1) Used Crankcase Oil
- (2) Used Automatic Transmission Fluid (ATF)
- (3) Used Hydraulic Oil
- (4) #2 Fuel Oil (Diesel Fuel)*

* #2 Fuel Oil (Diesel Fuel) should be mixed with other used oil to increase the viscosity and allow proper fuel delivery.

DO NOT put flammable or corrosive substances such as gasoline, chlorinated solvents, paint thinner, or any other unsafe substance in the oil supply tank.



WARNING: To avoid serious injury or death, do not weld or allow open flames within 35 feet of the used oil supply tank.

- (1) The tank installation must comply with NFPA 30 and NFPA 31 fire codes.
- (2) The tank should be installed on a slight slope with a drain on the low end to allow sludge and water to be removed from the bottom of the tank.
- (3) All oil lines must be constructed of copper, steel, or brass components. DO NOT use rubber, plastic, or any other inappropriate material for oil lines.
- (4) Be sure to follow all instructions for tank installation in the Owner's Manual.

TIPS FOR MAINTAINING HIGH PERFORMANCE

TURN OFF POWER TO THE BURNER IF A CALL FOR HEAT IS NOT EXPECTED FOR MORE THAN A WEEK.

Explanation:

If the green power light is "on" at the burner, the oil temperature is being maintained by the 200W heater element. If this oil temperature is maintained over a long period of time (like over the summer months) without a call for heat, the nozzle adapter heater block is more likely to accumulate carbon build up which may cause a plugged nozzle. Flip the breaker "off" at the panel or turn the Burner Power Switch "off" located on the junction box on top of the unit.

DO NOT ALLOW ANY UNAPPROVED MATERIAL INTO THE OIL STORAGE TANK.

Explanation:

Material placed in the oil storage tank will eventually be delivered to the burner. Antifreeze and water will not ignite and will cause the heating equipment to shut down.

DO NOT USE EXHAUST FANS THAT CREATE A VACUUM IN THE BUILDING.

Explanation:

A backdraft at the heating equipment will damage critical burner components. If your shop requires exhaust fans there must be adequate make up air so that the furnace can maintain a proper natural draft. If there is insufficient make up air, install make up air louvers or use a relay to open the wall thermostat circuit to ensure the burner does not fire when an exhaust fan is in use.

FURNACE ASSEMBLY

Follow the steps below for furnace assembly (refer to Figure 1):

- (1) Install the *blower*
- (2) Determine the appropriate *air discharge configuration*
 - *Unit Heater (Free Air with no ductwork)*
 - *Central Furnace (ductwork installed)*
- (3) Install the combustion chamber *target*
- (4) Install the *burner*
- (5) Install the *connector block and oil line*

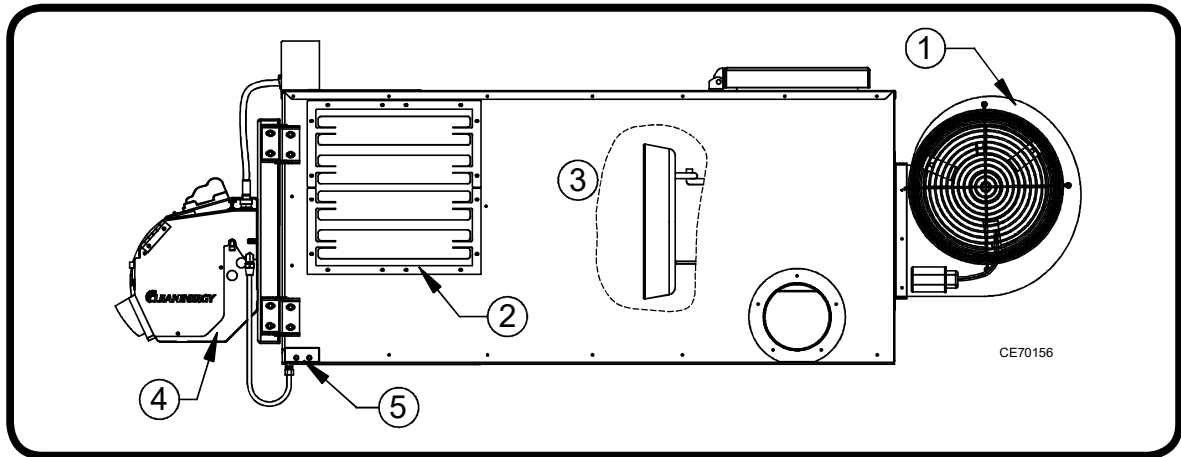

Figure 1: Typical Furnace Assembly

Installing the Blower:



WARNING: Blower guards must be in place to prevent personal injury. NEVER operate the furnace without all guards in place!

NOTICE: The blower motor is designed to operate with the guards in place. Without the guards in place the blower will move more air which may overload and damage the blower motor.

NOTICE: The blower must be mounted with the “bubble” turned up. If the blower is not mounted in this position, the internal air flow through the furnace cabinet will change which may cause the unit to cycle on high limit.

Installing the Blower (CE-140, CE-180, and CE-250):

- (1) Refer to Figure 2.
- (2) Remove the three shipping brackets (CE 250 blower assembly only).
- (3) Place the blower inside the mounting angles on the back of the furnace with the blower bubble turned up.
- (4) Use the included #10 self-drilling screws to secure the blower housing to the mounting angle brackets on the back of the furnace cabinet.
- (5) Connect the flexible conduit from the blower motor to the rear electrical box.
- (6) Connect the wire leads according to the electrical schematic label in the rear junction box.
- (7) Fasten the blower guards with the remaining #10 self-drilling screws to each side of the blower.

FURNACE ASSEMBLY

CE 250 Blower Assembly Only

Remove shipping brackets (3) mounted over the motor shaft

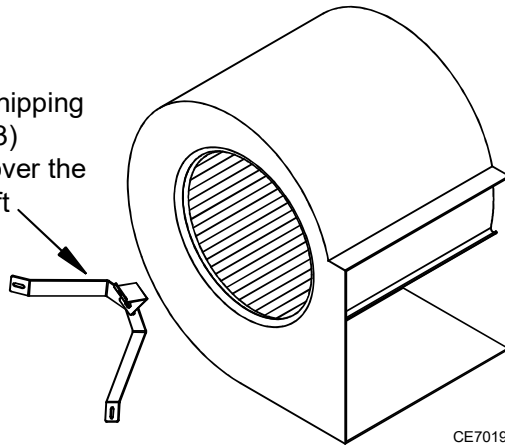

CE70197

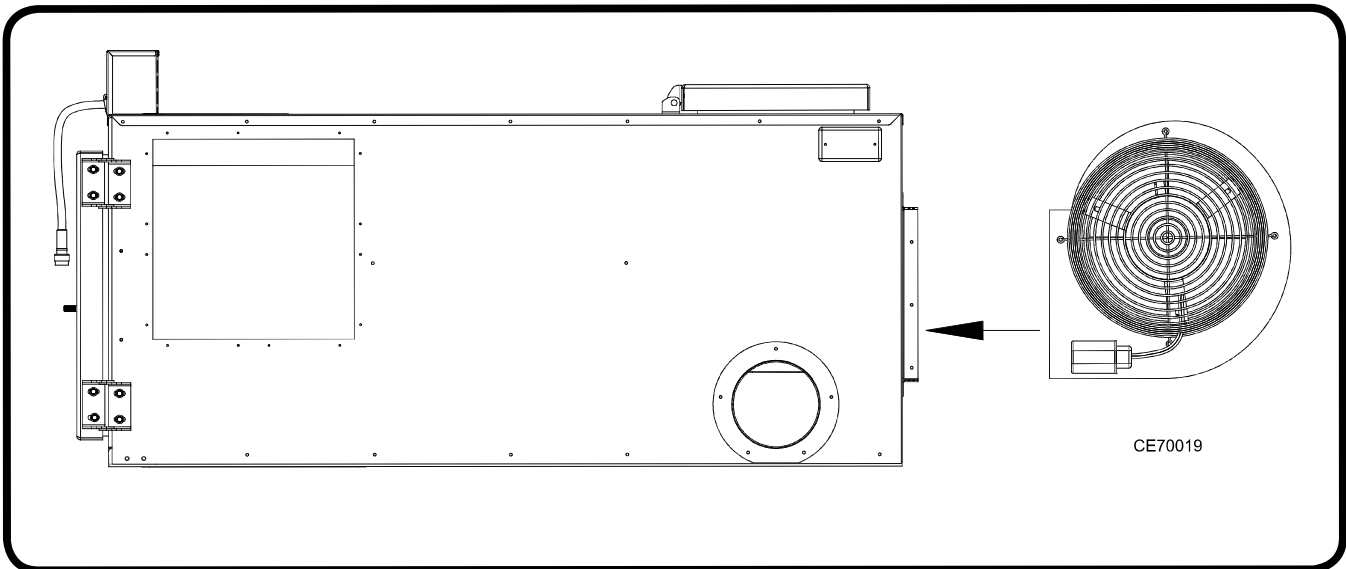

CE70019

Figure 2: Blower Assembly Installation (CE-140, CE-180, and CE-250)



CAUTION: Three shipping brackets are installed on the CE 250 Blower Assembly and must be removed before operation.

Installing the Blower (CE-330 and CE-440):

- (1) Refer to Figure 2A.
- (2) Place the blower inside the mounting angles on the back of the furnace with the blower bubble turned up. Move the mounting angle brackets tight against the blower.
- (3) Use the included #10 self-drilling screws to secure the blower housing to the mounting angle brackets on the back of the furnace cabinet.
- (4) Secure the motor to the motor bracket with the supplied hardware.
- (5) Fasten the motor bracket and tensioning bracket to the blower according to dimensions shown in Figure 2A.

FURNACE ASSEMBLY

- (6) Install the blower pulley and motor pulley. Use a straight edge to make sure the pulleys are installed on the same plane.
- (7) Install the belt on the pulleys and tighten the tensioning bracket(s) to maintain proper belt tension.
- (8) Connect the flexible conduit from the blower motor to the rear electrical box and connect the wire leads according to the electrical schematic label in the rear junction box. Wire the motor for high voltage (220V) as shown on the motor label. The motor needs to rotate CCW shaft end when mounted as shown in Figure 2A.
- (9) Rotate the motor in the cradle mount until the capacitor box or conduit is up against the motor bracket and tighten the screws around cradle mount on the motor. This will keep the motor from “spinning” and damaging components when it first starts up.
- (10) Fasten the blower guards with the remaining #10 self-drilling screws to each side of the blower.

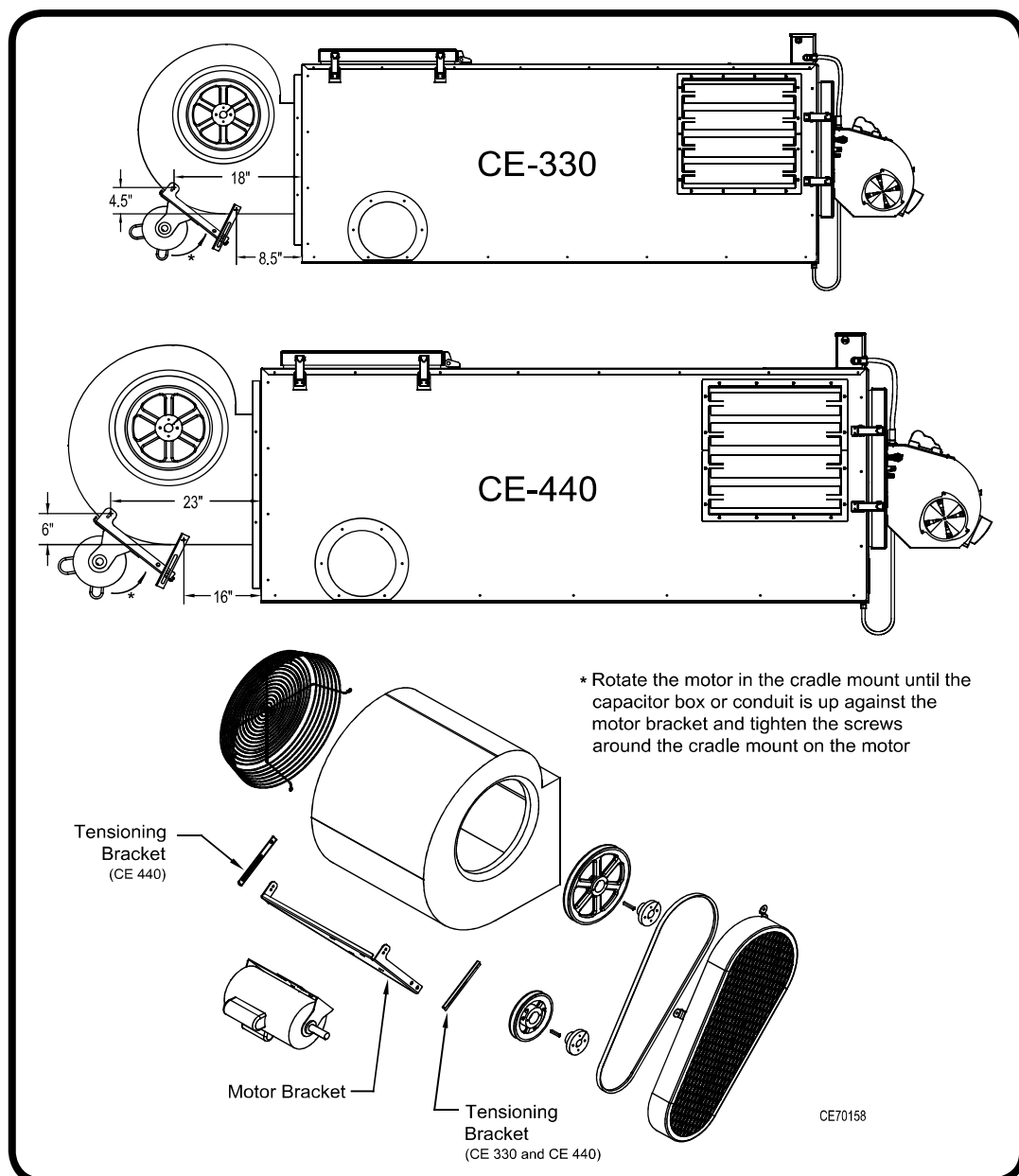

Figure 2A: Blower Assembly Installation (CE-330)

FURNACE ASSEMBLY

Air Discharge Configurations:

Your Clean Energy Heating System may be installed in one of two ways:

1. **Unit Heater** - Louvers are installed over the air outlet opening(s) to direct the hot air flow in the desired direction.
2. **Central Furnace (Static Pressure)** - Duct work applications with less than 0.30" W.C. (inches of water column). Louvers are NOT installed. Ductwork is installed over the side air outlet opening(s) to direct the hot air flow.

NOTICE: A qualified electrician should check the amp draw of the blower motor. Do not operate the blower motor over 85% of the amp rating on the motor nameplate.

1. **Unit Heater Configuration**

There are several options for mounting the louvers on a unit heater for free air applications. Refer to Figures 3, 4, and 5. Cover the unused air outlet openings with the blank covers provided (one is painted and one is galvanized). The blank covers can be split in two.

NOTICE: When splitting a side opening horizontally, the louvers should be positioned in the top half of the air outlet opening. When splitting a side opening vertically, the louvers should be positioned in the front (closest to the burner) half of the air outlet opening.

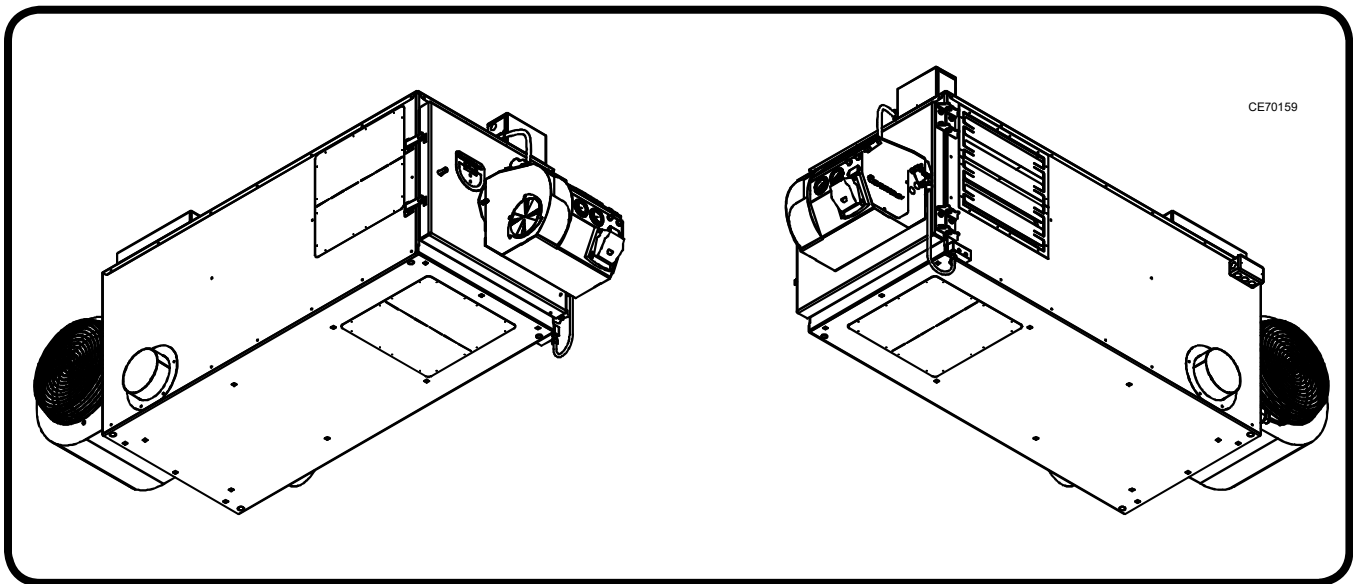

Figure 3: Installing the Louvers
One Side Air Outlet Fully Open

FURNACE ASSEMBLY

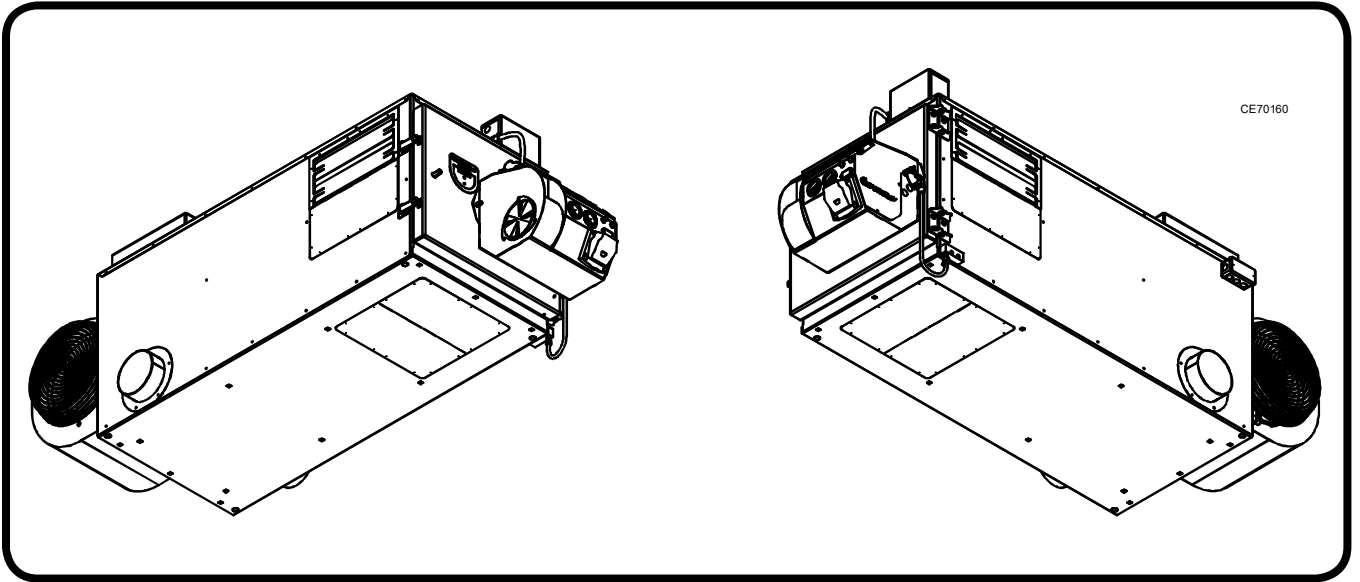

Figure 4: Installing the Louvers
Splitting the Air Outlet Openings Between Both Sides

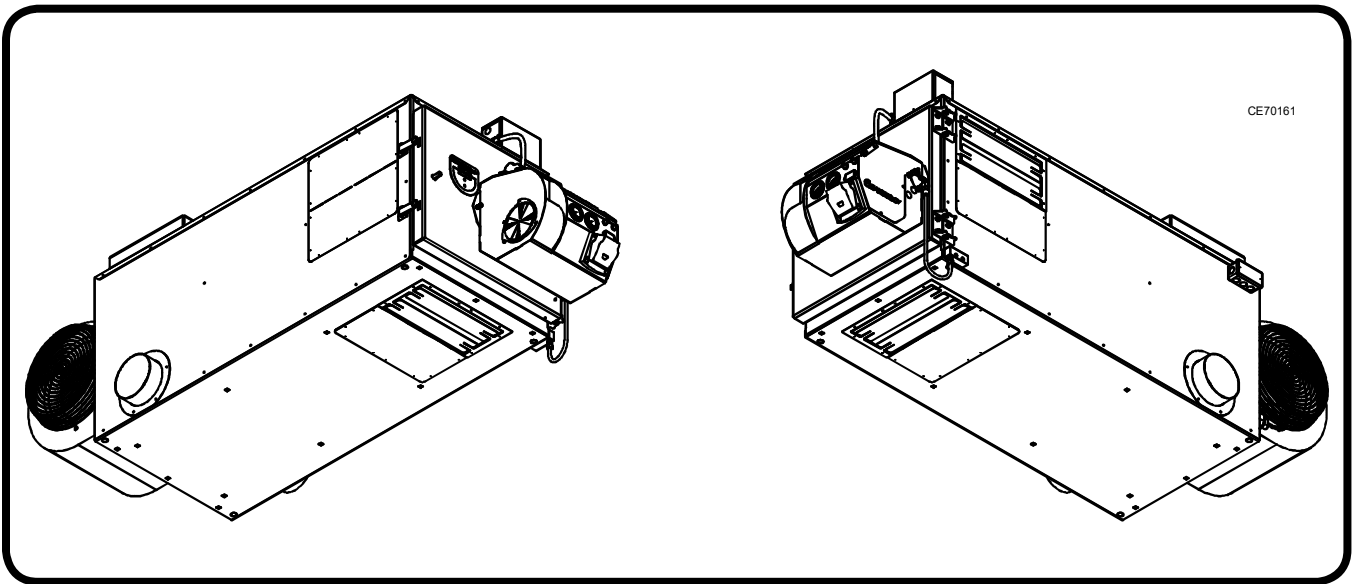

Figure 5: Installing the Louvers
Splitting the Air Outlet Openings Between one Side and Bottom

FURNACE ASSEMBLY

2. Central Furnace (Static Pressure - Less than 0.30" w.c.)

DO NOT install the louvers. Install the ductwork directly over the desired SIDE air outlet opening(s).

NOTICE: DO NOT install ductwork over the bottom air outlet opening. Proper air flow will not be maintained and furnace damage may occur.

NOTICE: DO NOT install return ductwork to the blower. Proper air flow will not be maintained and furnace damage may occur.

NOTICE: A qualified HVAC engineer should design the ductwork for your application and determine the static pressure of the ductwork installed. Existing ductwork may not be suitable for this furnace. Only connect ductwork to the side air outlets on the furnace. DO NOT install ductwork on the bottom air outlet of the furnace. Refer to the tables below for air flow specifications.

CE-140

Louvers Mounted on Furnace	No Louvers Installed / Ductwork Installed on Furnace
No Ductwork	0.30" W.C.
1700 CFM	1400 CFM

CE-180

Louvers Mounted on Furnace	No Louvers Installed / Ductwork Installed on Furnace
No Ductwork	0.30" W.C.
1700 CFM	1400 CFM

CE-250

Louvers Mounted on Furnace	No Louvers Installed / Ductwork Installed on Furnace
No Ductwork	0.30" W.C.
2700 CFM	2400 CFM

CE-330

Louvers Mounted on Furnace	No Louvers Installed / Ductwork Installed on Furnace
No Ductwork	0.30" W.C.
3700 CFM	3300 CFM

CE-440

Louvers Mounted on Furnace	No Louvers Installed / Ductwork Installed on Furnace
No Ductwork	0.25" W.C.
4900 CFM	4400 CFM

FURNACE ASSEMBLY

Installing the Combustion Chamber Target:

NOTICE: Damage to the combustion chamber may occur if the furnace is used with a damaged or missing target. Inspect the target regularly for proper positioning and wear.

- (1) Refer to Figure 6 to view the proper position of the combustion chamber target.
- (2) Open the front door of the furnace by loosening the two over-center latches and swinging the door open.
- (3) Guide the target toward the back of the combustion chamber. Hang the loop on the back of the target on the hook welded to the back of the combustion chamber.
- (4) Close the front door and secure the two over center-latches.

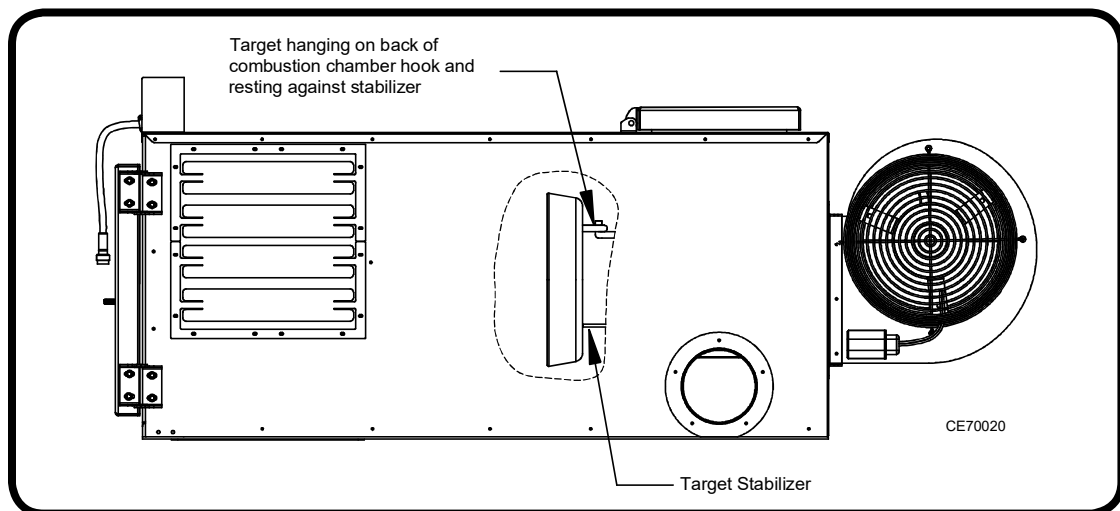

Figure 6: Proper Position of the Combustion Chamber Target

Installing the Burner:

NOTICE: The nozzle, electrode, and retention head may need adjustment after shipping and installation. The nozzle should remain centered in the retention head. Refer to Figure 7 for proper dimensions.

- (1) Remove the two serrated flange nuts from the front door.
- (2) Slide the blast tube of the burner through the throat of the front door.
- (3) Fasten the burner to the front door by tightening the two serrated flange nuts.

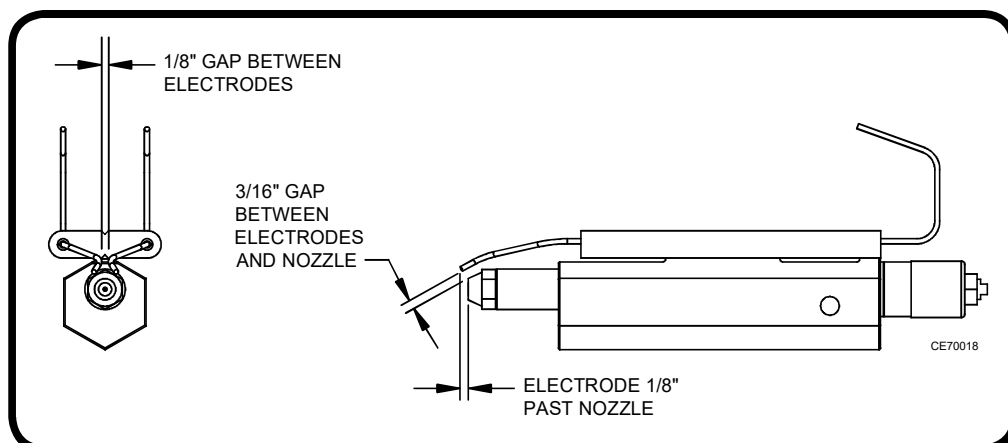

Figure 7: Nozzle and Electrode Settings

FURNACE ASSEMBLY



WARNING: To prevent the risk of electrical shock, shut OFF main power to the furnace before connecting or disconnecting the burner power cord.

- (4) Refer to Figure 8
- (5) Line up the key in the receptacle with the slot in the cord.
- (6) Tighten the electrical cord when in position.

NOTICE: Make sure the plug and receptacle are properly aligned. The ground prong in the receptacle is longer than the other prongs and must be lined up properly.

Installing the Connector Block and Oil Line:

- (1) Refer to Figure 9 to position the connector block.
- (2) Fasten the connector block to the side of the furnace with the bolts provided.
- (3) Install the supplied 3/8" copper tubing from the swivel fitting in the connector block to the burner.

NOTICE: The connector block with the swivel fitting must be used to allow the front door to swing open properly. If the connector block is not used the oil line will need to be disconnected before the door is opened.

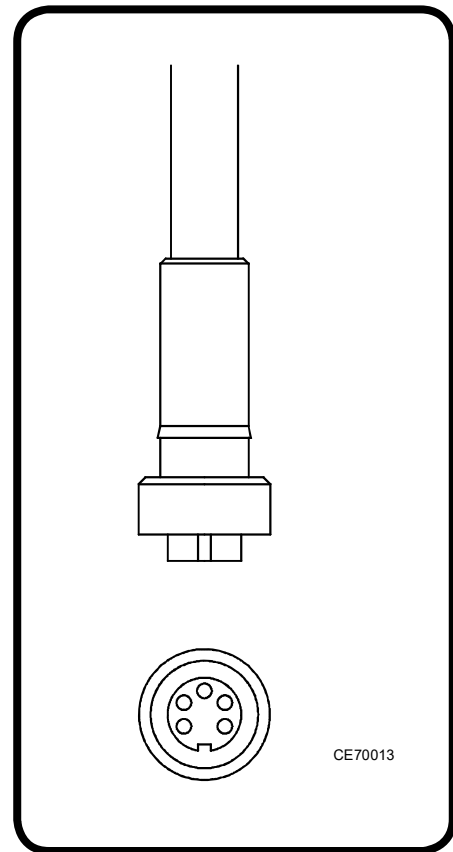

Figure 8: Installing the Burner Power Cord

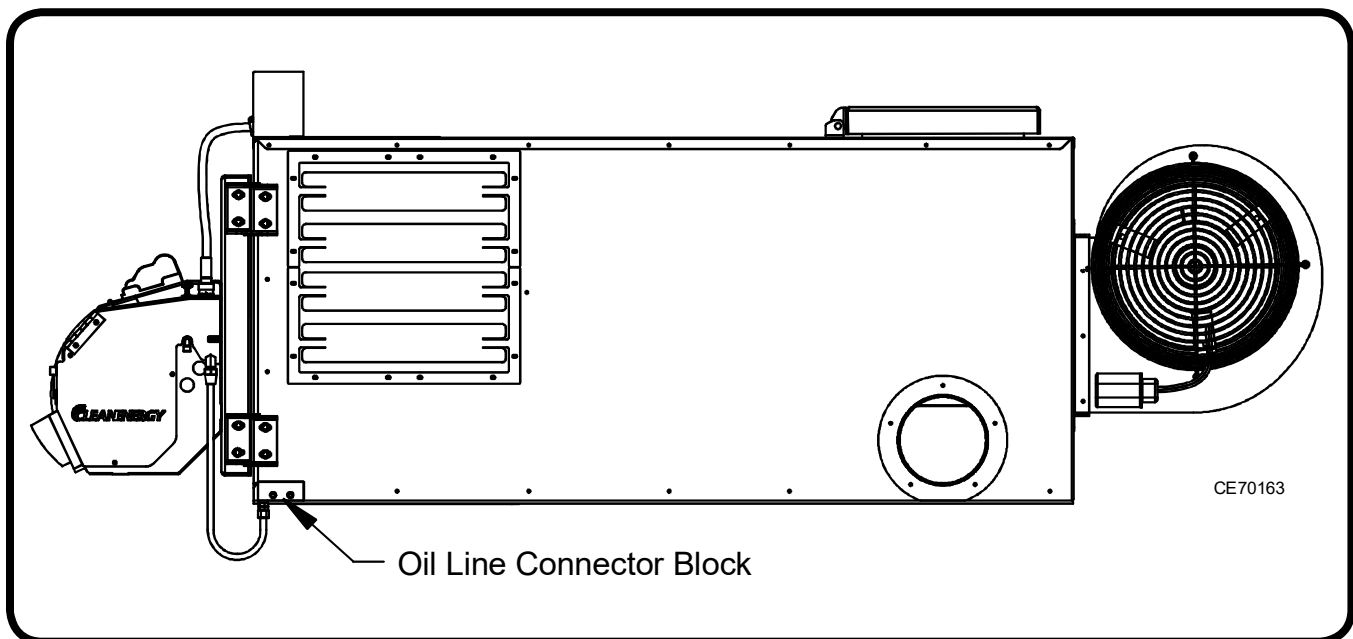

Figure 9: Installing the Connector Block and Oil Line

FURNACE INSTALLATION

Refer to Figure 10 for a typical furnace installation illustration.

Installation of your furnace will include the following steps:

- (1) Selecting a location
- (2) Mounting the furnace in position
- (3) Connecting the electrical supply
- (4) Installing the chimney components
- (5) Positioning the oil storage tank
- (6) Installing the metering pump and oil lines
- (7) Connecting the compressed air line
- (8) Installing the wall thermostat
- (9) Inspecting the furnace installation

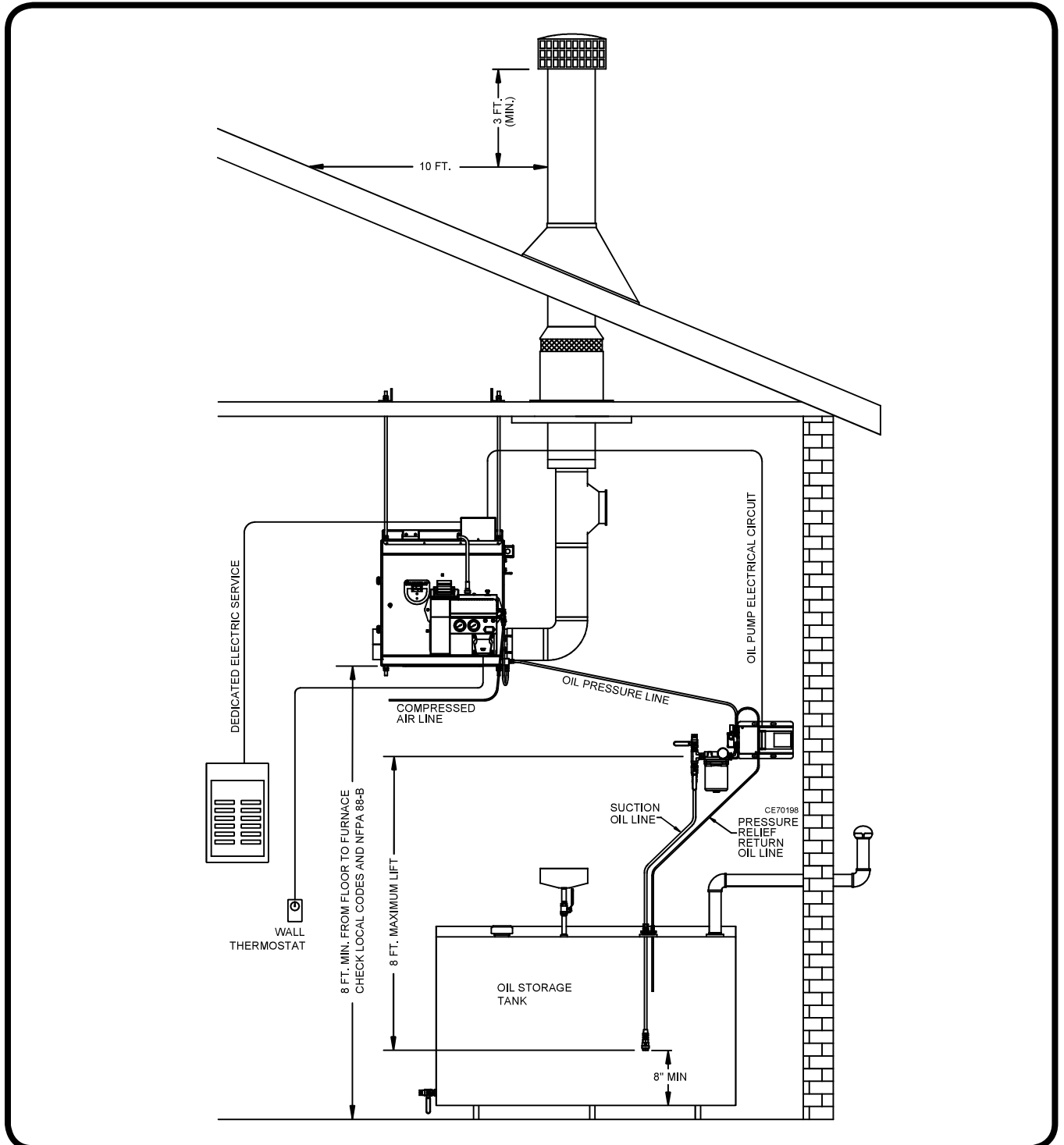

Figure 10: Typical Furnace Installation

FURNACE INSTALLATION



WARNING: Carefully follow all installation instructions for safe and efficient operation.

Select a location:

There are several considerations when selecting a location for your new furnace:

- (1) Do not obstruct shop personnel or equipment
- (2) Find a location where the warm air will be evenly distributed.
- (3) The installation must meet the clearance to combustible material requirements (Figure 11)
- (4) The location must be safely accessible for maintenance and service
- (5) The installation must comply with all local codes and regulations
- (6) Keep the stack / chimney system simple. A complicated stack with multiple elbows and long horizontal runs will reduce the natural draft of the unit which can damage critical burner components.

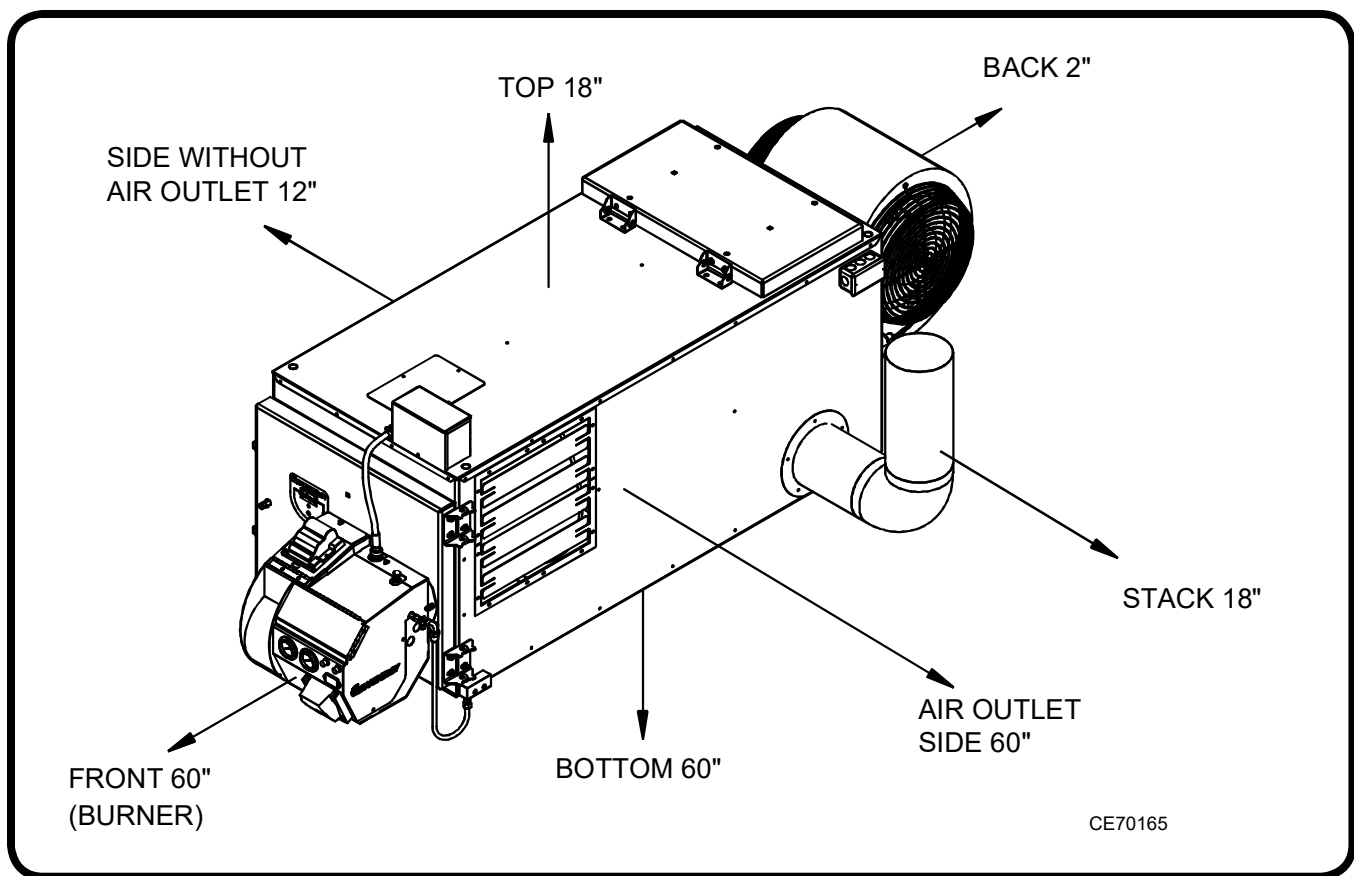

Figure 11: Clearances to Combustible Materials

Minimum Distances from Combustible Materials

UNIT HEATER
(with side warm air outlet)

Front (burner)	60"
Back (blower)	2"
Side with air outlet	60"
Side with no air outlet	12"
Top of furnace	18"
Bottom	18"
Single wall chimney pieces	18"

UNIT HEATER
(with bottom warm air outlet)

Front (burner)	60"
Back (blower)	2"
Side	12"
Top of furnace	18"
Bottom	60"
Single wall chimney pieces	18"

CENTRAL FURNACE

Front (burner)	60"
Back (blower)	2"
Side	12"
Top of furnace	18"
Bottom	18"
Ductwork (within 3ft of furnace)	6"
Single wall chimney pieces	18"

FURNACE INSTALLATION

Mounting the furnace in position:



WARNING: Codes may require that the furnace is mounted eight (8) feet above the floor if there is potential for gasoline fumes. Refer to NFPA 88B, Standard for Repair Garages.



WARNING: Use adequate structural members to safely bear the weight of the furnace when either hanging it from the ceiling or mounting it on a stand.

HANGING THE FURNACE FROM THE CEILING:

- (1) Refer to Figure 12 for a typical ceiling hung illustration.
- (2) Remove the kerf cut holes in the corners of the top and bottom of the furnace cabinet.
- (3) Insert all-thread rod (minimum 1/2") through the cabinet and put a washer and two nuts on the bottom.
- (4) Use adequately sized square tubing or angle iron across sufficient structural members to safely carry the weight of the furnace.
- (5) Put a washer and two nuts on the top of each all-thread rod
- (6) Use a level to ensure the furnace is hanging level front-to-back and side-to-side.

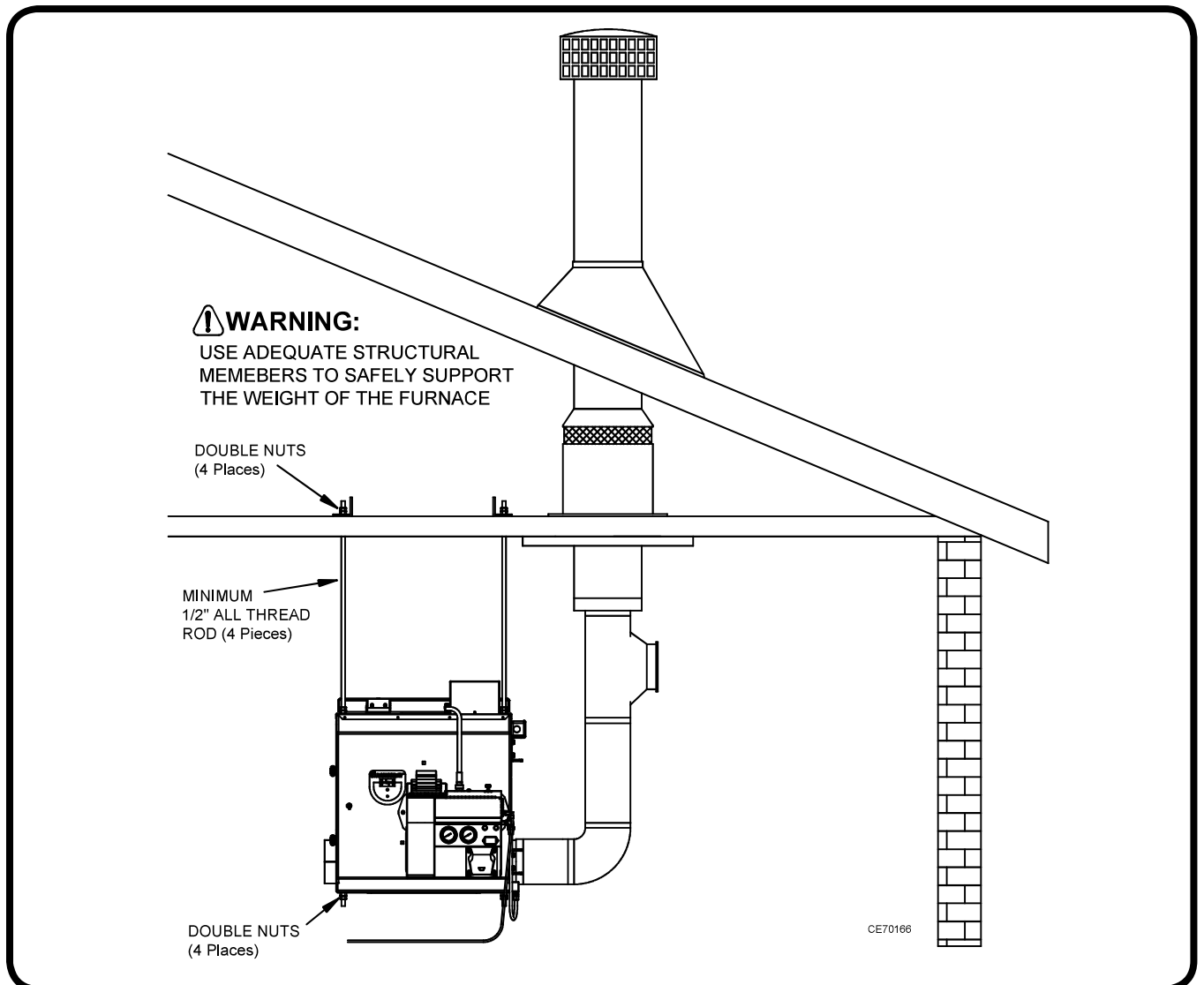

Figure 12: Typical Ceiling Hung Furnace

FURNACE INSTALLATION

MOUNTING THE FURNACE ON A STAND:



WARNING: The stand must be made of steel (non-combustible material) and must be anchored to ensure stability.

- (1) Refer to Figure 13 for a typical furnace mounted on a stand.
- (2) The material used must be adequately sized to support the weight of the furnace.

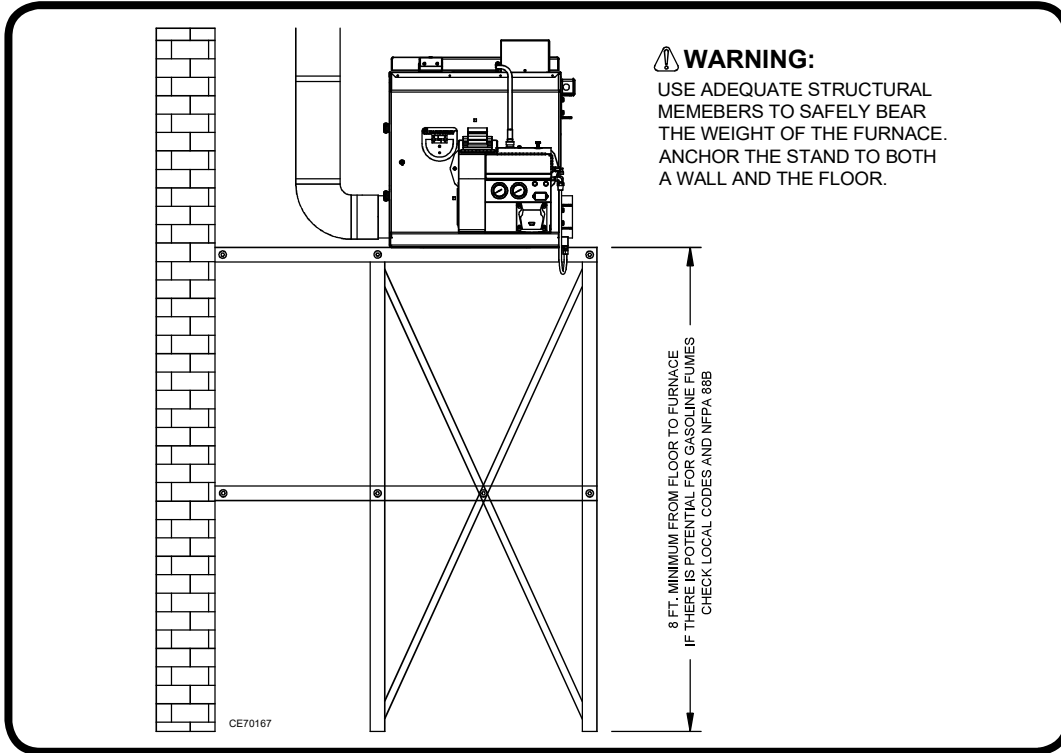

Figure 13: Typical Furnace Mounted on a Stand

Connecting the electrical supply to the furnace:



WARNING: Shut off main power to the furnace before making any electrical connections. ONLY a qualified electrician should run wire and make connections to the furnace. All wires must be the proper gauge and run in approved electrical conduit. All wiring must meet the requirements of the National Electrical Code.

Electrical Requirements:

CE-140

120 V / 60 Hz
Single Phase
20 Amp dedicated circuit

CE-180

120 V / 60 Hz
Single Phase
20 Amp dedicated circuit

CE-250

120 V / 60 Hz
Single Phase
30 Amp dedicated circuit

CE-330 / CE-440

230 V / 60 Hz
Single Phase
30 Amp dedicated circuit

NOTE: The CE-330 and CE-440 need a four wire feed. Two 115V Line voltage legs, a neutral, and a ground.

FURNACE INSTALLATION

- (1) Install a dedicated electrical circuit to the junction box indicated below.

FRONT ELECTRICAL BOX by the burner on the **CE-140, CE-180, and CE-250**

BACK ELECTRICAL BOX by the blower on the **CE-330 and CE-440**

- (2) Connect the wires according to the label found on the inside of the junction box cover or in the *wire diagrams* section of this manual. Use stranded copper wire to ensure a secure connection.

Installing the chimney components:



DANGER: Follow manufacturers instructions and requirements for clearances (air spaces) to combustible material for the Double Wall “Class A” Insulated chimney material.



WARNING: UL “Class A” All Fuel Approved to 2100°F Chimney (UL - 103 HT Approved) must be used through any building penetration and for any exterior stack. Unapproved stack material and/or installation can create a fire hazard. Contact Clean Energy Heating Systems, LLC to purchase approved stack material for your installation.



CAUTION: Using single wall stack on the exterior of your building will cause the stack gases to cool rapidly and adversely affect the natural draft of the furnace. This will create a back draft and may damage critical burner components.

- (1) Refer to Figure 14 for a typical through-the-roof chimney illustration and Figure 15 for a typical through-the-wall chimney illustration.
- (2) Observe the following requirements when installing the chimney:
 - The CE-140, CE-180 and CE-250 furnace models require 6” I.D. stack components.
 - The CE-330 and CE-440 furnace models require 8” I.D. stack components.
 - Have a minimum of 10 feet vertical chimney to ensure -.02” w.c. draft over fire.
 - Keep horizontal runs short. Slope any horizontal sections at least 1/4” per foot.
 - Keep the stack installation simple. Multiple turns and horizontal runs will reduce the natural draft of the furnace which may damage critical burner components.
- (3) Single wall stack may be used inside the building. Observe proper clearances from combustibles. Do not put single wall stack in areas that may create a burn hazard to personnel.
- (4) Install a barometric damper, as shown in Figures 15 and 16, so that proper draft can be maintained. Follow the instructions provided with the damper for proper installation.
- (5) Use double wall “Class A” insulated stack material when making a penetration through the ceiling, roof or side wall of your building. Install proper flashing around the exterior penetration of the stack to make a water tight seal.
- (6) Install a “Class A” non-restrictive stack cap only.



CAUTION: If your building utilizes an exhaust fan, ensure that there is adequate make-up air available. Lack of make-up air will create a vacuum in your building which will result in a back draft at the furnace. A back draft will damage critical burner components. If there is insufficient make up air, install make up air louvers or use a relay to open the wall thermostat circuit to ensure the burner does not fire when an exhaust fan is in use.

FURNACE INSTALLATION

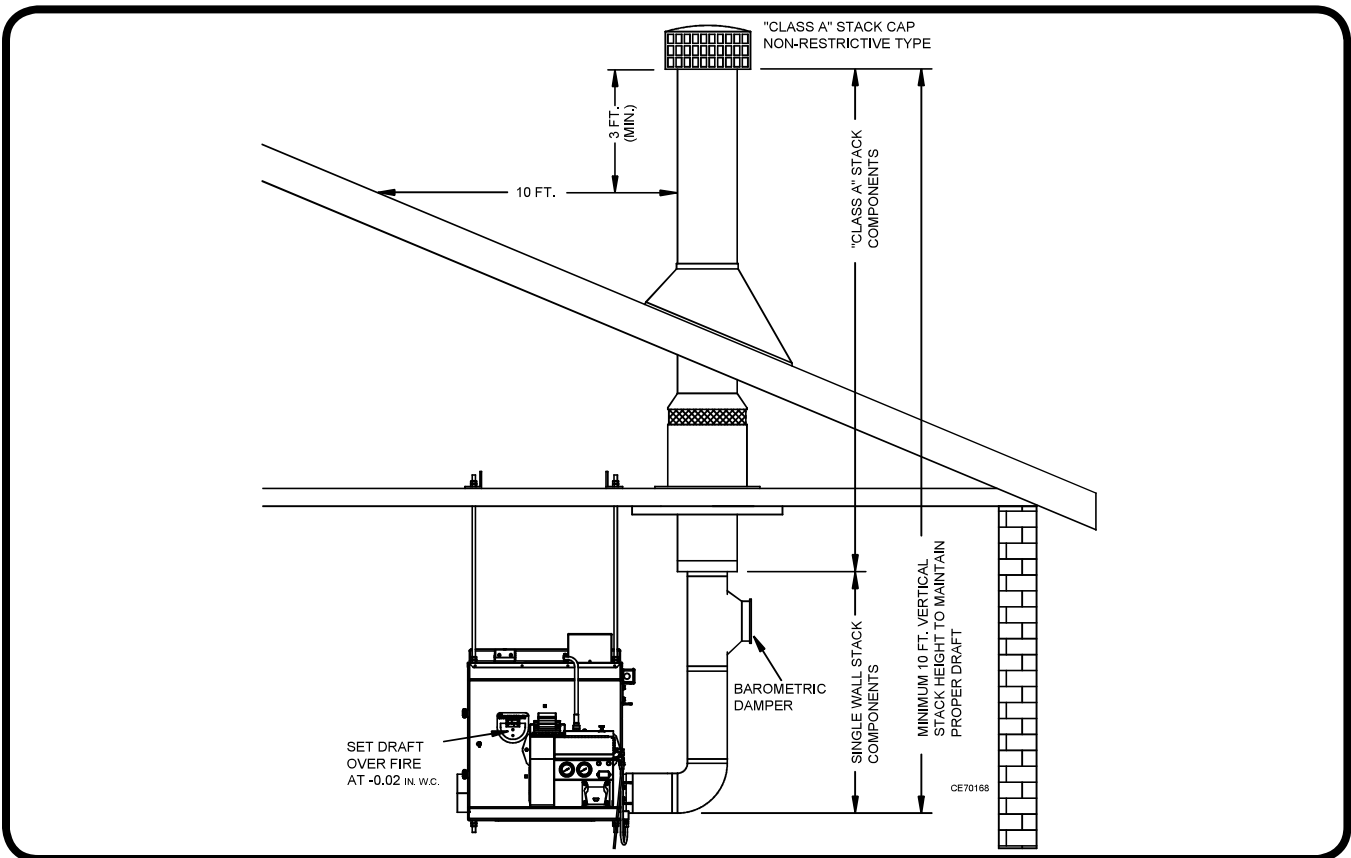

Figure 14: Typical Through-the-Roof Chimney Illustration

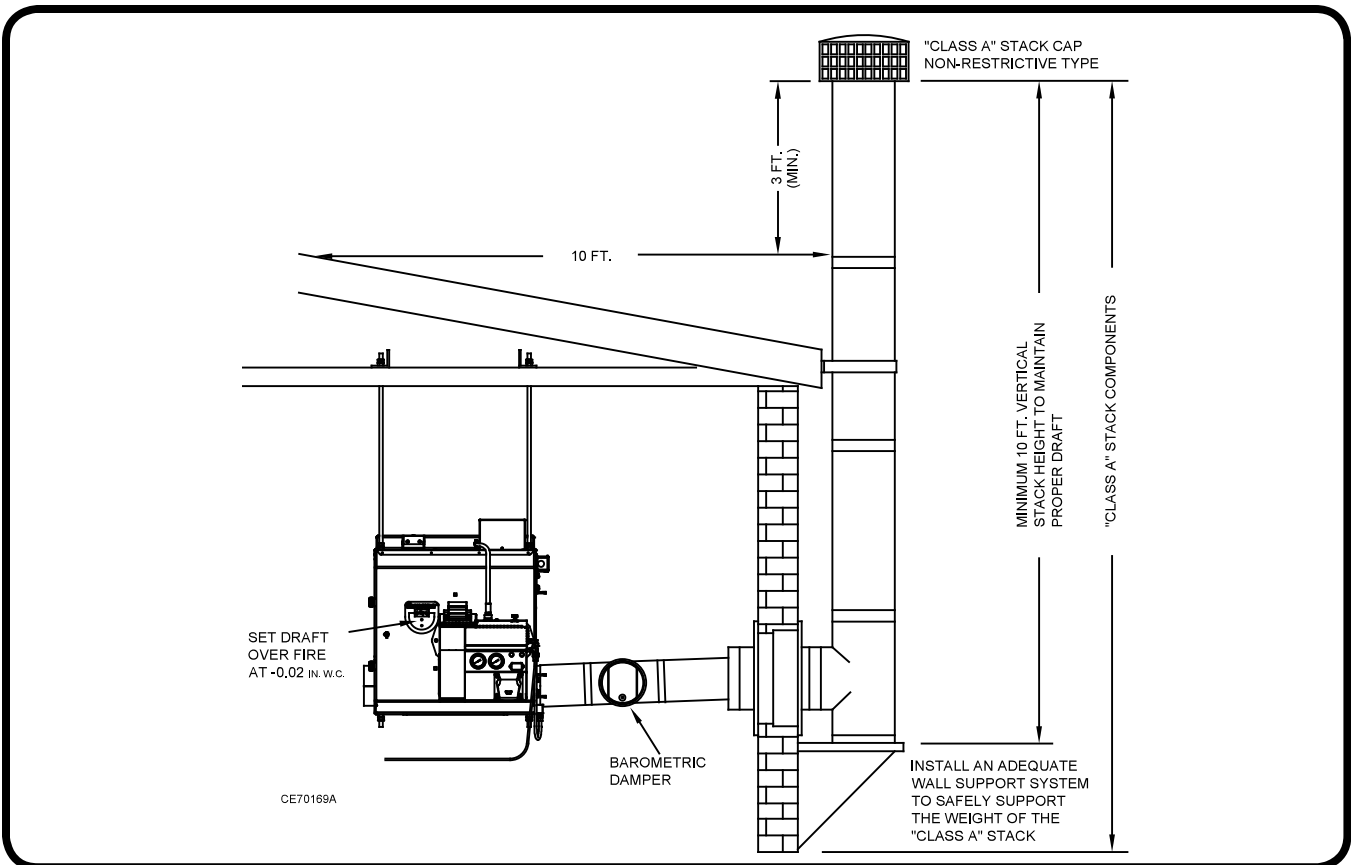

Figure 15: Typical Through-the-Wall Chimney Illustration

FURNACE INSTALLATION

Oil storage tank setup:

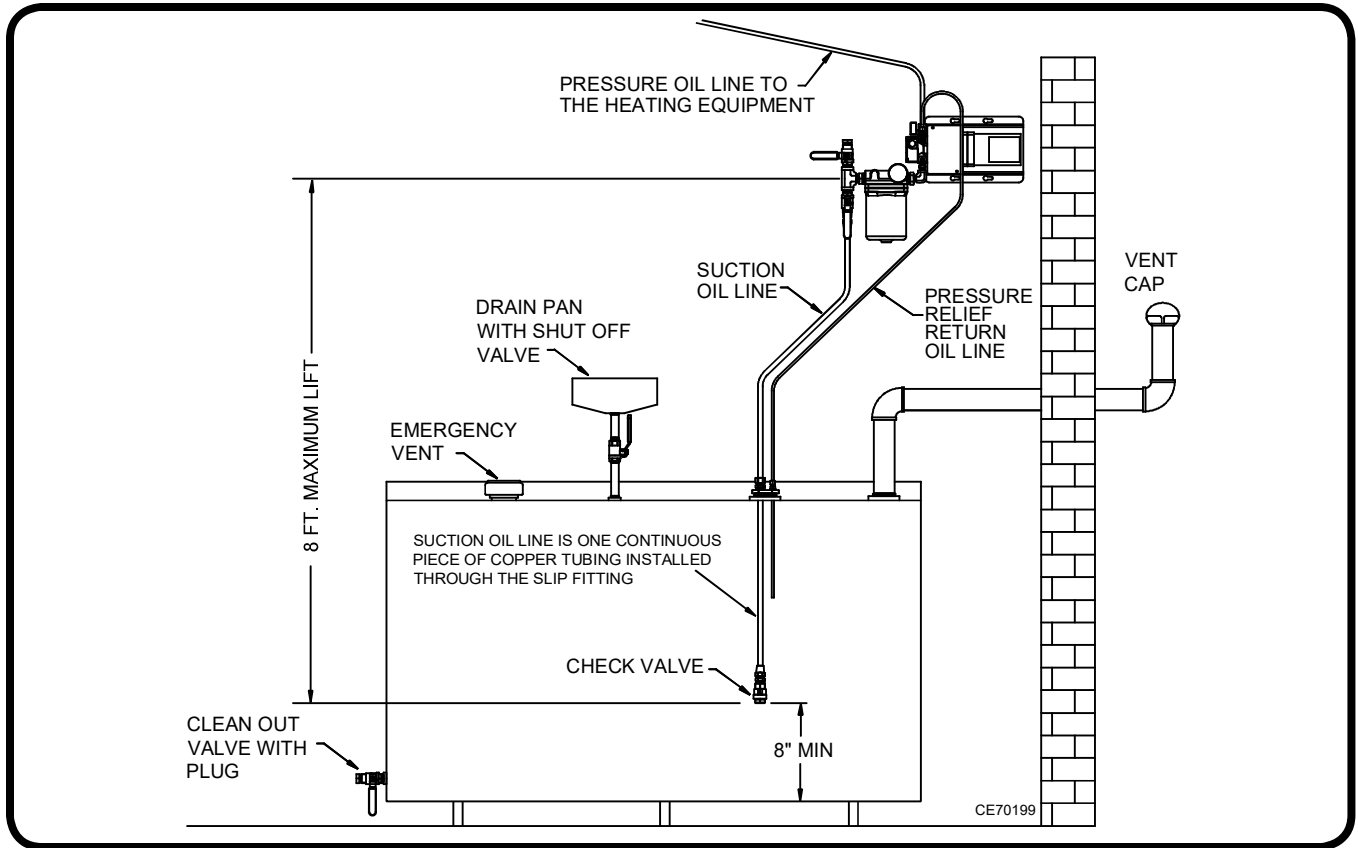

Figure 16: Typical Oil Storage Tank Installation

- (1) Refer to Figure 16 for a typical oil storage tank setup.
- (2) The tank must be installed according to all NFPA requirements and State and Local codes.
- (3) An inside tank is recommended.
- (4) Locate the tank in a position that will allow the oil pump to be mounted as close as possible
- (5) Only use a tank with a drain on the bottom. Over time, dirt and sludge will naturally accumulate on the bottom of the tank and there must be a way of removing this unwanted material.
- (6) Some state and local codes require the tank to be vented to the outside.
- (7) Educate all personnel what substances are allowed to be added to the used oil supply and apply the provided tank warning label near the fill location.

Installing the metering pump system and oil lines:



CAUTION: The metering pump must be mounted above the oil tank. The pump is not designed to take head pressure. If the pump is below the level of oil in the tank the pump seals may begin to leak.

Metering Pump Installation Guidelines:

- (1) Use non-hardening thread sealer for all threaded pipe fittings.

NOTICE: DO NOT use teflon tape on any oil or air fittings. The use of teflon tape on any fittings will VOID the warranty.

- (2) The pump must be installed with the shaft in the horizontal position and the oil outlet pointing up.

NOTICE: The gauge arrow on the front of the pump head must be pointing up.

FURNACE INSTALLATION

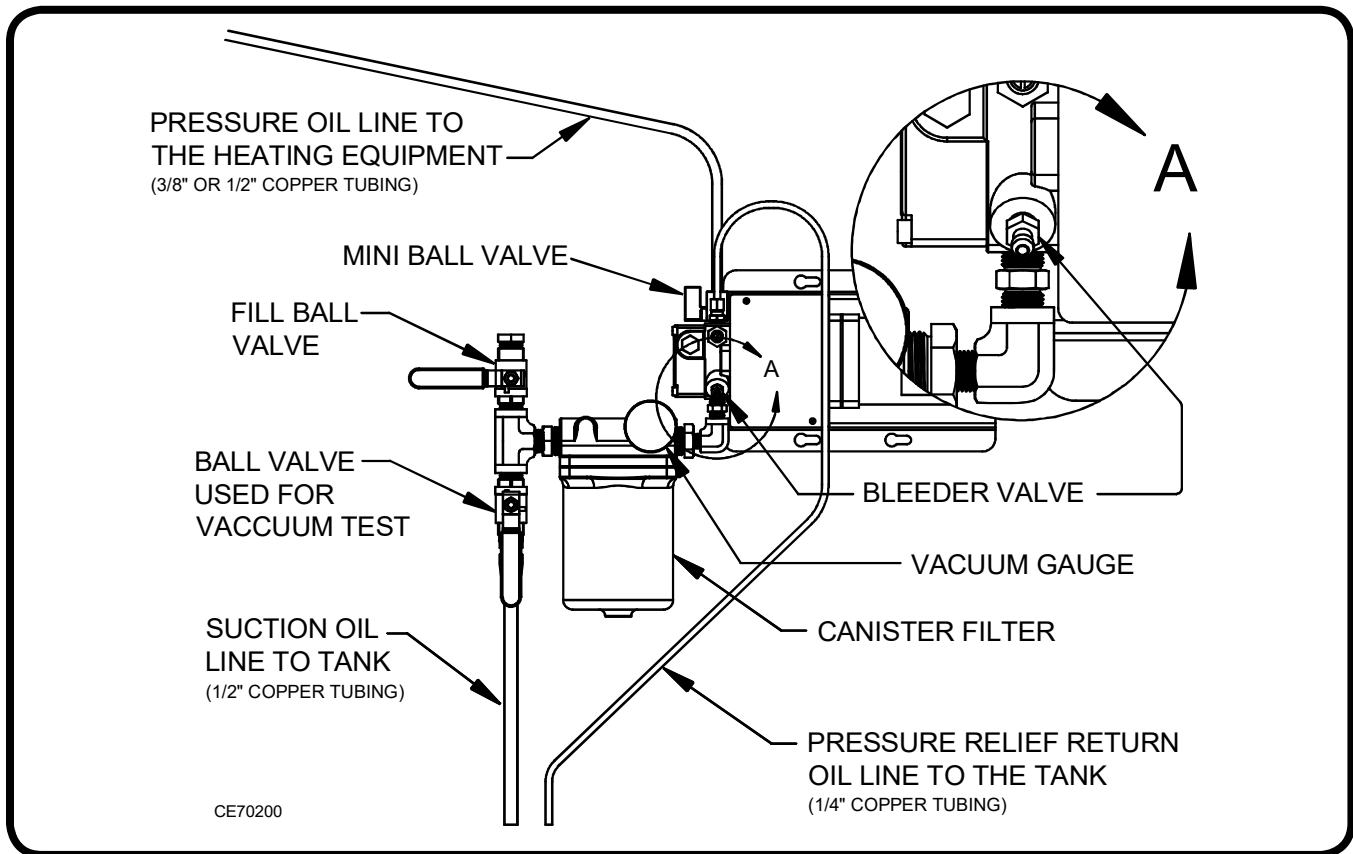

- Figure 17: Typical Metering Pump Installation (Standard Mounting on a Wall)
- (3) The metering pump system is a fixed displacement pump. The pump shaft is driven by a gearmotor at a specific rpm for each furnace model. This delivers a constant flow (gph) of fuel. Change in oil viscosity and temperature have very little effect on fuel flow. Therefore no oil pressure adjustment is needed for the metering pump system.
 - (4) The metering pump must be mounted as close to the tank as possible. The suction oil line (length of oil line from the bottom of the tank up to the pump) must not exceed 8 vertical feet. Every 3 horizontal feet of suction line reduces the maximum allowable vertical lift by 1 foot.
 - (5) The suction oil line must be a minimum of 8" from the bottom of the tank to reduce the likelihood of sludge and/or water being delivered to the furnace.
 - (6) The metering pump system is not weatherproof. Mount the pump indoors only.

Mounting the metering pump assembly:

NOTICE: The metering pump system comes assembled for standard mounting on a wall.

STANDARD MOUNTING:

- (1) Refer to Figure 17 for a typical metering pump installation (standard mounting on a wall).
- (2) Use appropriate hardware to mount the metering pump system to the wall.
- (3) Keep the pump assembly as close to the tank as possible.

ALTERNATE MOUNTING:

- (1) Refer to Figure 18 for an illustration of the alternate horizontal mounting.
- (2) Loosen the pump head and rotate it 90°. The pump assembly may now be mounted in the horizontal position as on a shelf.

FURNACE INSTALLATION

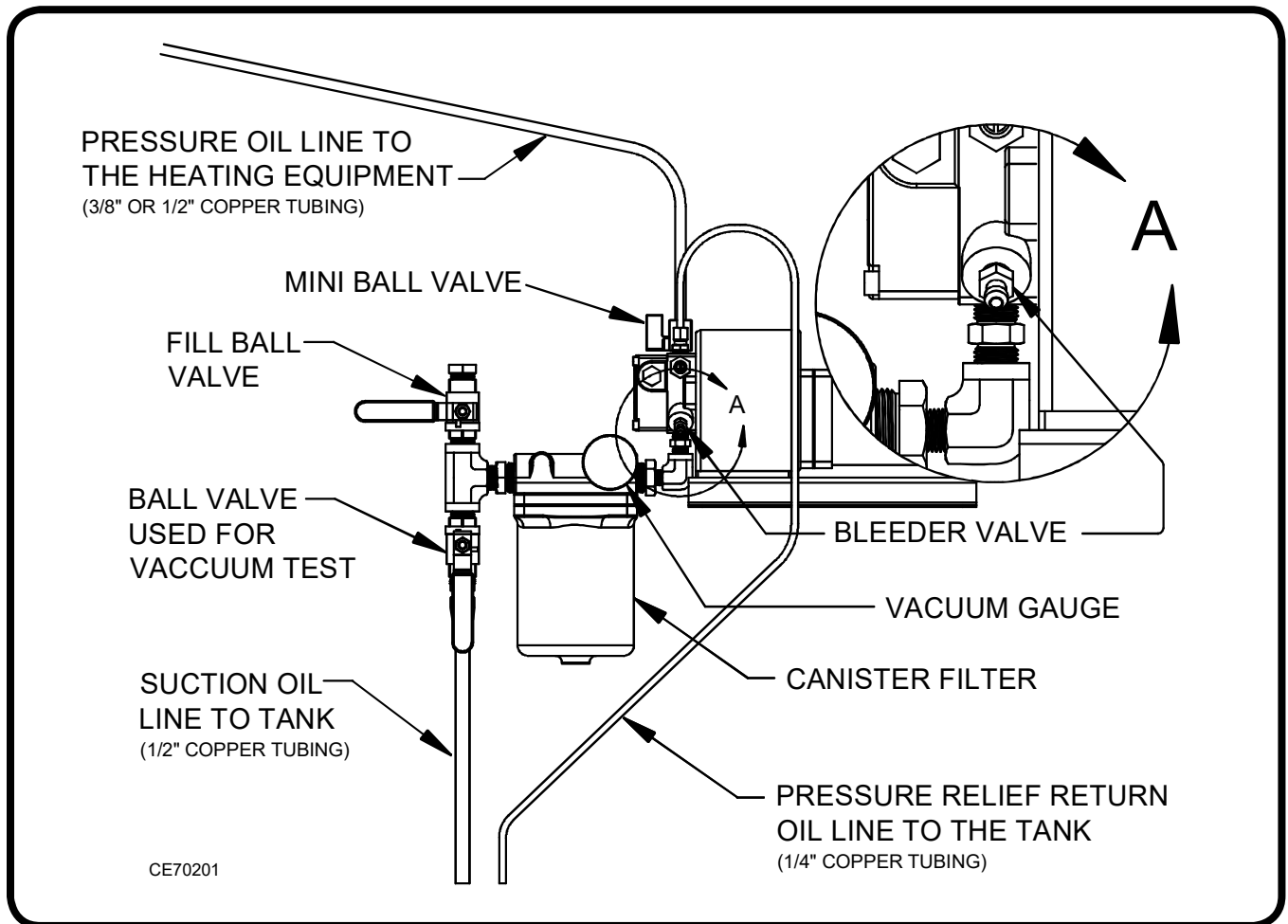

Figure 18: Alternate Horizontal Metering Pump Mounting

Installing the suction oil line:

- (1) Refer to Figure 19.
- (2) Measure the height of the tank. Reduce this measurement by 12" and mark the 1/2" copper suction line tubing at this length (connecting the flare fitting and foot valve will put the bottom of the suction line at the recommended 8" from the bottom of the tank).
- (3) Install the 1/2" MNPT slip-through fitting into the side of the 2" duplex fitting marked "S".
- (4) Slide the 1/2" copper suction line tubing through the slip fitting in the 2" duplex fitting up until the mark that was made indicating 12" less than the height of the tank.
- (5) Install the 1/2" flare fitting into the foot valve (arrow on foot valve pointing toward the flare).
- (6) Flare the 1/2" copper suction line tubing and install it on the foot valve.
- (7) Insert the suction tubing into the tank and tighten the 2" duplex fitting.
- (8) Carefully bend the 1/2" copper suction line tubing up to the filter and cut it to length.
- (9) Flare the 1/2" copper suction line tubing and install it on the filter.

Installing the pressure relief oil line back to the tank:

- (1) Refer to Figure 19 and 20.
- (2) Install the 1/2" MNPTx1/4" compression fitting into the side of the 2" duplex fitting marked "R".
- (3) Run a piece of 1/4" copper tubing from the pump relief valve back to the tank.

FURNACE INSTALLATION

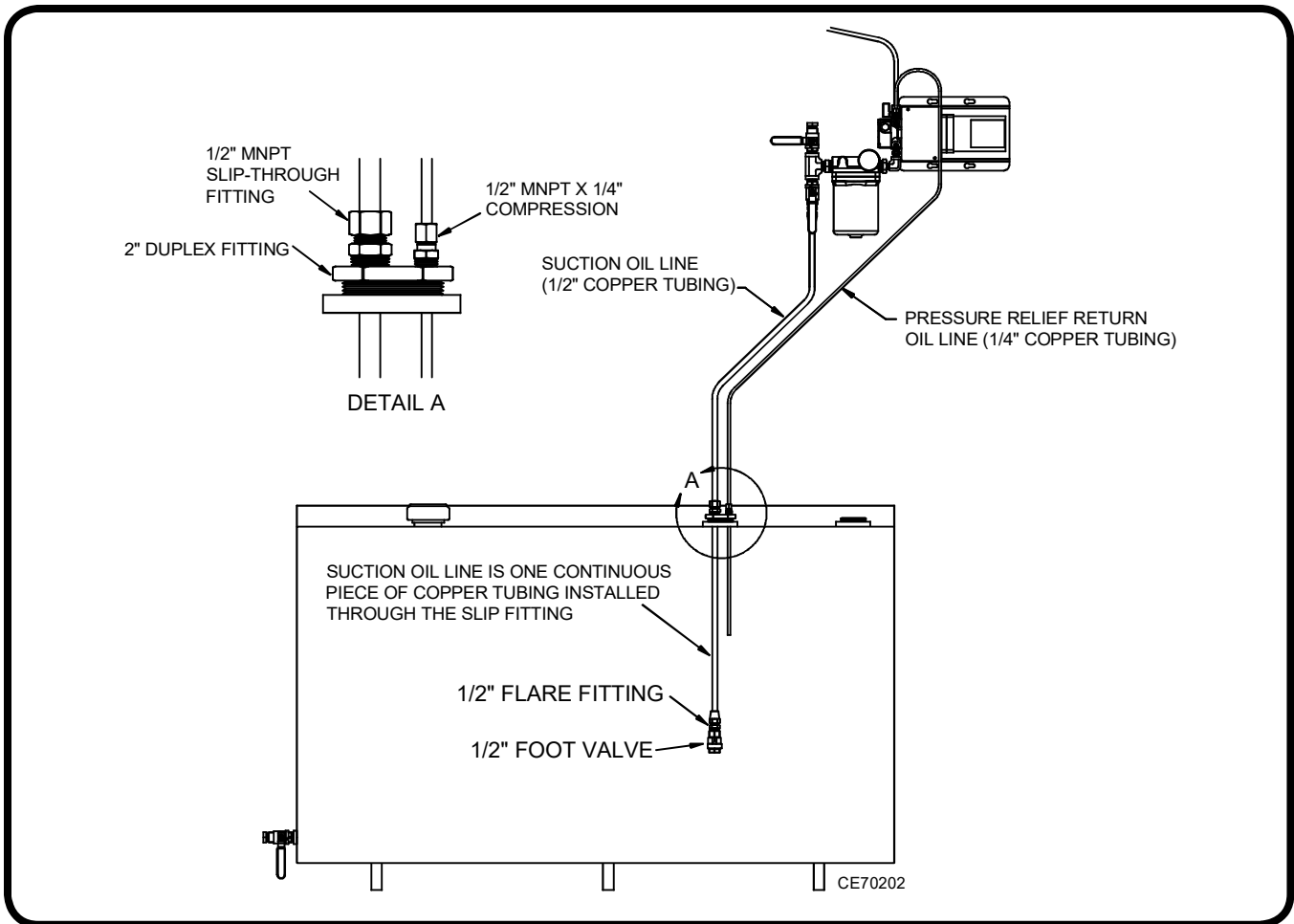

Figure 19: Installing the Suction Oil Line

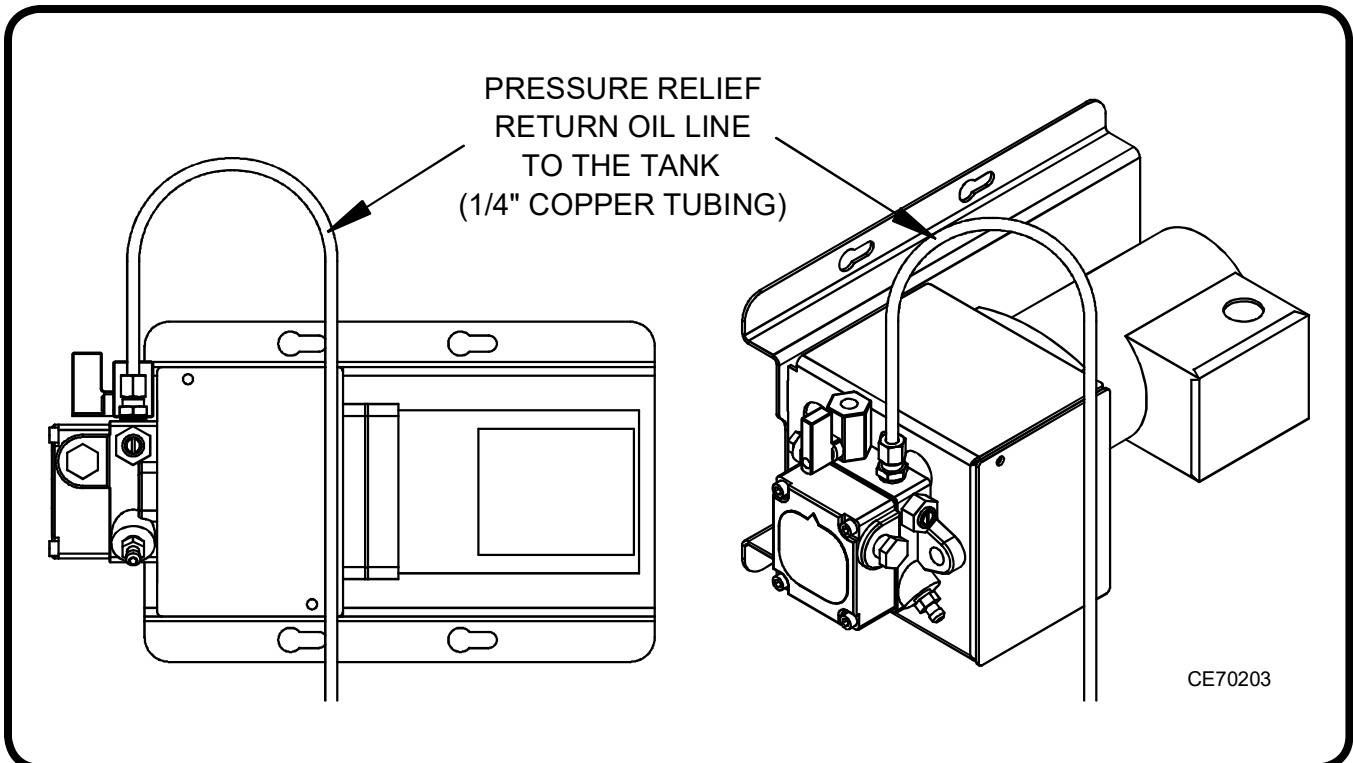

Figure 20: Metering Pump Pressure Relief Valve

FURNACE INSTALLATION

Installing the pressure oil line to the furnace:

- (1) Refer to Figure 21.
- (2) Determine the length of copper tubing needed for the pressure line (from pump to furnace) and use the appropriate sized tubing. If the pressure line is less than 100 feet, 3/8" copper tubing can be used. If the pressure line is greater than 100 feet, use 1/2" copper tubing. An adapter fitting may be needed when using 1/2" copper to make the connection between the tubing fitting and mini ball valve (50039 - 1/8 MNPT x 1/4 FNPT).

NOTICE: There are installations that will operate well with a long pressure oil line. However, to ensure proper performance with variables such as oil temperature and viscosity, Clean Energy Heating Systems does not recommend exceeding 150 feet of total pressure oil line.

- (3) It is ideal to have the pressure oil line sloping up from the pump to the furnace. This reduces the risk of air pockets and nuisance shut downs.
- (4) Refer to Figure 22.
- (5) Connect the pressure oil line to the aluminum connector block on the side of the furnace.

NOTICE: By connecting the oil line to the connector block, the swivel fitting is utilized which allows the front clean out door to be opened without disconnecting the oil line.

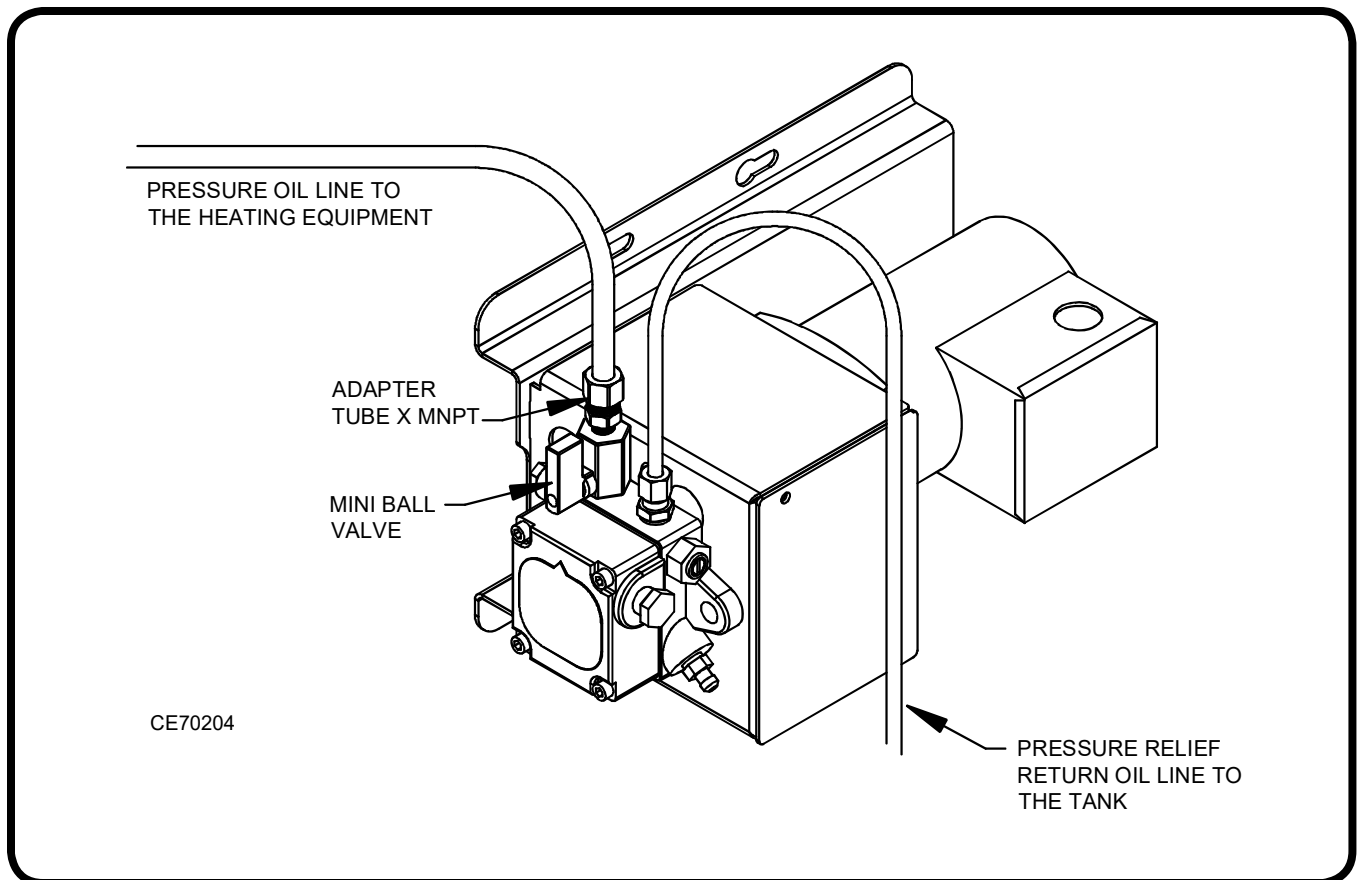

Figure 21: Metering Pump Oil Line Connections

FURNACE INSTALLATION

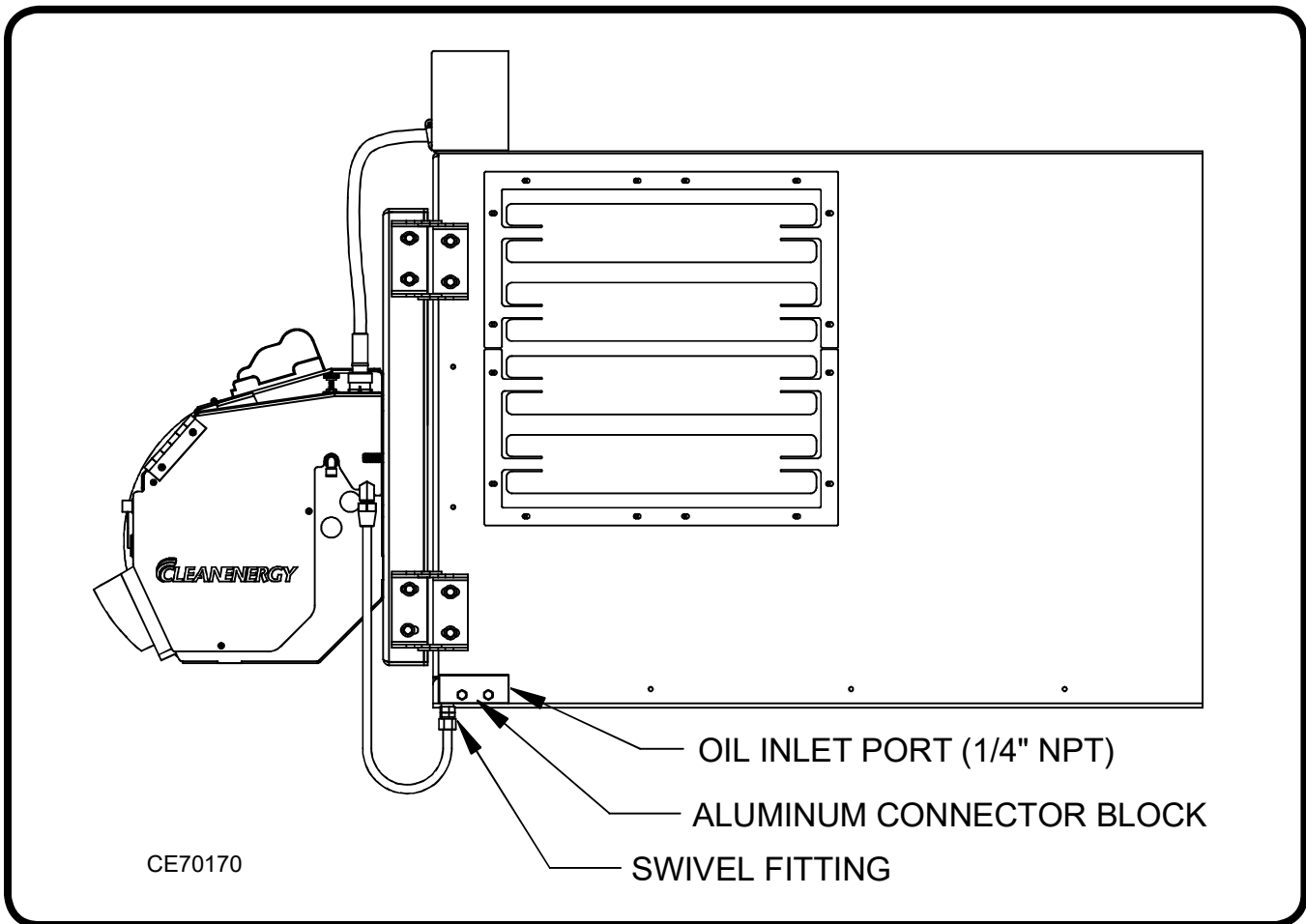

Figure 22: Connecting the Pressure Oil Line to the Connector Block

Connecting the Compressed Air Line:

NOTICE: DO NOT use teflon tape on any oil or air fittings. The use of teflon tape on any fittings will VOID the warranty.

- (1) Refer to Figure 23.
- (2) mount a water trap / air regulator (adjusted to 50 psi) and shut-off valve close to the furnace.
- (3) Run a flexible hose to the air inlet on the side of the burner. Carefully secure the air line to ensure it does not come in contact with any hot metal surfaces.

NOTICE: If a flexible hose is not used the air line will need to be disconnected from the burner to swing the front door open.

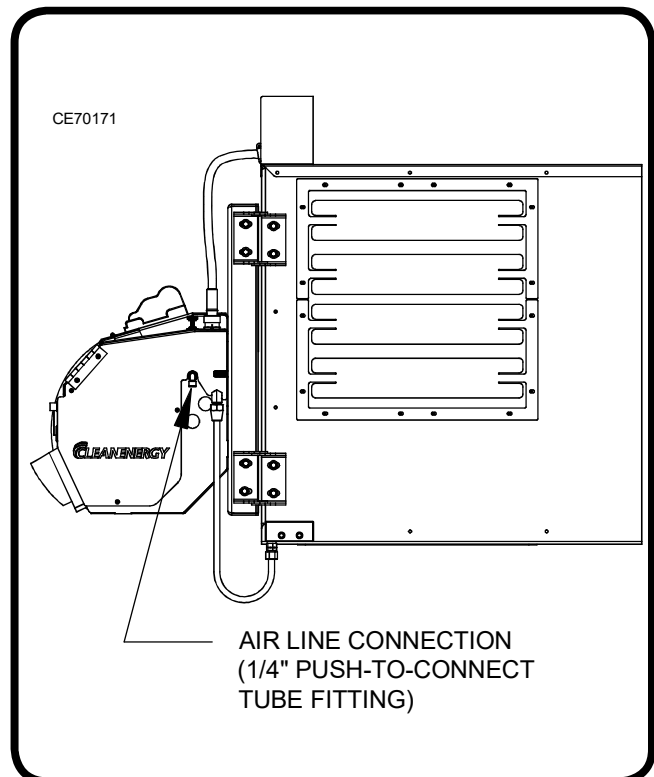

Figure 23: Installing the Air Line

FURNACE INSTALLATION

Installing the wall thermostat:

- (1) Use the digital wall thermostat provided with the furnace.
- (2) Mount the wall thermostat according to the instructions provided with the thermostat.
- (2) Mount the thermostat on an interior wall and in a location that will be shielded from drastic temperature changes such as a door being opened.
- (3) Mount the thermostat at eye level to allow for easy viewing and adjustment.
- (4) Run the thermostat cable from the wall thermostat to the T-T terminals on the oil primary control of the burner. When connecting the wires refer to the burner wire diagram in this manual and to the wire diagram included with the thermostat .

Changing the Wall Thermostat Batteries:

- (1) A low battery indicator will be displayed on the front screen to indicate low battery strength.
- (2) There is about a two week time frame to replace the batteries once the indicator comes on.
- (3) Follow instructions included with the thermostat to replace the batteries.

Inspecting the Furnace Installation:

NOTICE: The furnace installation should be inspected by qualified personnel before it is operated to ensure all state and local codes are followed.



CAUTION: Omitting or deviating from installation instructions in this manual may create hazardous operating conditions and void your warranty.

PREPARING THE METERING PUMP FOR START UP

- (1) Refer to Figure 24.
- (2) Remove the 1/2" NPT plug and open the ball valve on the inlet of the filter.
- (3) Pour oil into the inlet of the filter until the suction oil line, filter, and pump head are full.

NOTICE: A funnel can also be used to help direct the oil into the inlet of the filter.

- (4) Close the ball valve and insert the 1/2" NPT plug.
- (5) If the pressure oil line (from the pump to the furnace) is longer than 25 feet it is recommended to disconnect the oil line at the furnace and position a bucket under the line to catch the oil.

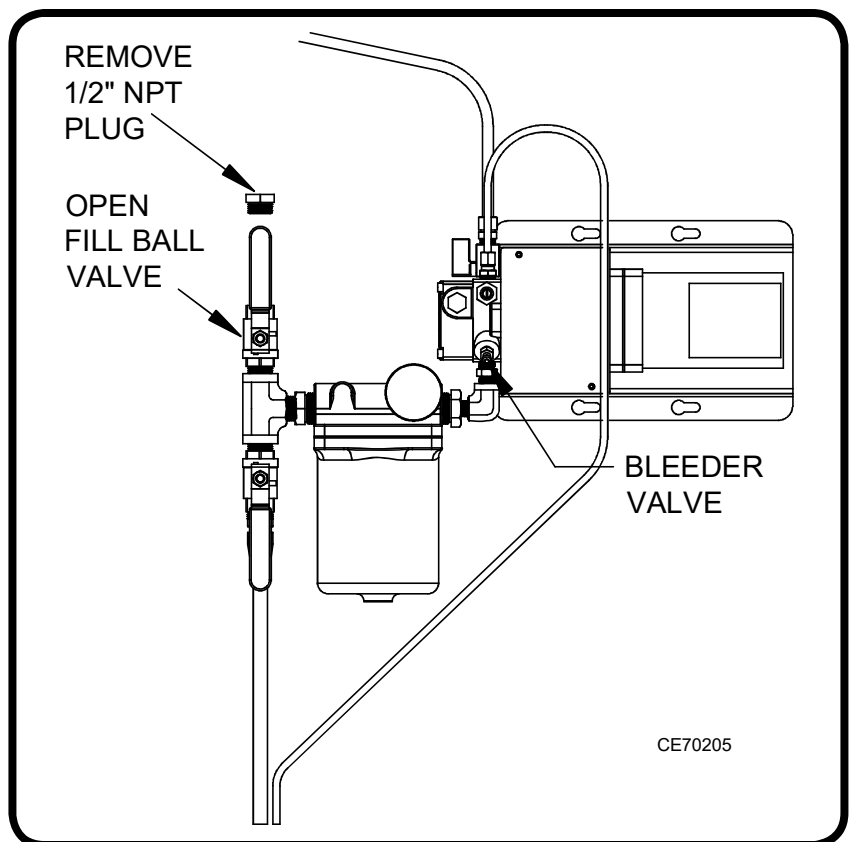

Figure 24: Priming the Metering Pump System

STARTING AND ADJUSTING THE BURNER

Preparing the burner for start up:

- (1) Plug the black cord into the top of the burner.
- (2) Turn on electrical power to the furnace.
- (3) Allow the burner heater element sufficient time to warm up the burner (time will vary according to ambient temperature). This usually takes 5 - 10 minutes. Once the burner has warmed up the "proving switch" will close and send power to the oil primary control.
- (4) Close the combustion air intake on the side of the burner. This will be opened up and adjusted once a flame is established.
- (5) Adjust the wall thermostat 10 - 20 °F above room temperature.
- (6) The burner should start when there is a call for heat. If the burner does not start, wait a few more minutes to ensure the burner is warmed up. If the burner still does not start try resetting the oil primary control (refer to the section on "Resetting the Oil Primary Control" in this manual).

Priming the oil pump:



CAUTION: Failure to prime the pump properly can result in unstable combustion, puff back, and heavy smoke.

- (1) After the burner starts, press and hold the reset button for 15 seconds until the small yellow light on the primary control ("Pump Prime") turns on (the burner will shut off).
- (2) Release the reset button. The yellow light will turn off and the burner will start again.
- (3) Within 15 seconds click (push and release) the reset button. This will transition the primary control to "Pump Prime" mode which will bypass the flame sensor and keep the pump on for 4 minutes.
- (4) Open the pump bleeder valve and purge all air bubbles from the pump (refer to figure 24).
- (5) After 4 minutes the yellow light on the primary control will turn off and the control will automatically return to standby mode.
- (6) Repeat steps 1 - 5 until the pump is fully primed and oil is delivered to the burner.

Adjusting the burner:

- (1) Once a flame is established adjust the combustion air intake and the compressed air pressure to maintain a healthy flame (refer to Figure 25).
- (2) The air intake plate on the left side of the burner can be adjusted to increase or decrease the pie shaped opening sizes to let in more or less combustion air.
- (3) The compressed air pressure can be adjusted by turning the knob on the air regulator.
- (4) Visually inspect the flame to ensure proper settings.
- (5) The flame should go 1/2 to 3/4 of the way down the combustion chamber, and should not impinge on any surface of the combustion chamber.

STARTING AND ADJUSTING THE BURNER

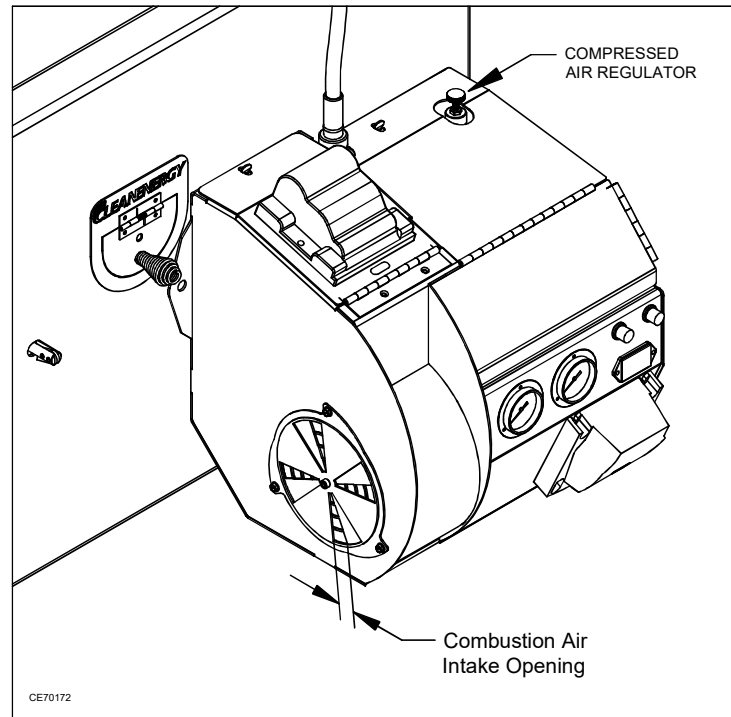

Each installation is unique. These measurements are for initial start-up only. Visually inspect the flame to make final adjustments for each installation.

<u>Model</u>	<u>Combustion Air Intake Opening</u>
CE 140	3/8"
CE 180	1/2"
CE 250	5/8"
CE 330	3/4"
CE-440	7/8"

Figure 25: Flame Adjustment

RESETTING THE OIL PRIMARY CONTROL



WARNING: Explosion and Fire Hazard. Failure to follow these instructions could result in heavy smoke emission, puff back, fire and smoke hazards.

- (1) Refer to Figure 26 to locate the oil primary control reset button.
- (2) Do not attempt to reset the burner if there is excess oil in the combustion chamber, vapor has accumulated in the unit, or when the furnace is hot.

Oil flooded furnace: Turn off power to the furnace and disconnect the burner cord. Open the clean out door and wipe out the accumulated oil before continuing.

Vapor filled furnace: Allow the unit to cool for 30 minutes and all vapors to dissipate before resetting the oil primary control.

- (3) When the combustion chamber has cooled, and there is no vapor or excess oil in the combustion chamber, push the reset button for 3 seconds and release.
- (4) If the burner does not restart contact the Clean Energy Heating Systems service department.

RESETTING THE OIL PRIMARY CONTROL

Resetting the burner from restricted lock out:

NOTICE: If the control locks out three times before a call for heat is satisfied, it will enter restricted lockout mode in order to limit the amount of unburned oil in the combustion chamber.

- (1) Push the reset button in for 15 seconds. Release the reset button when the red light turns off and the yellow light turns on.

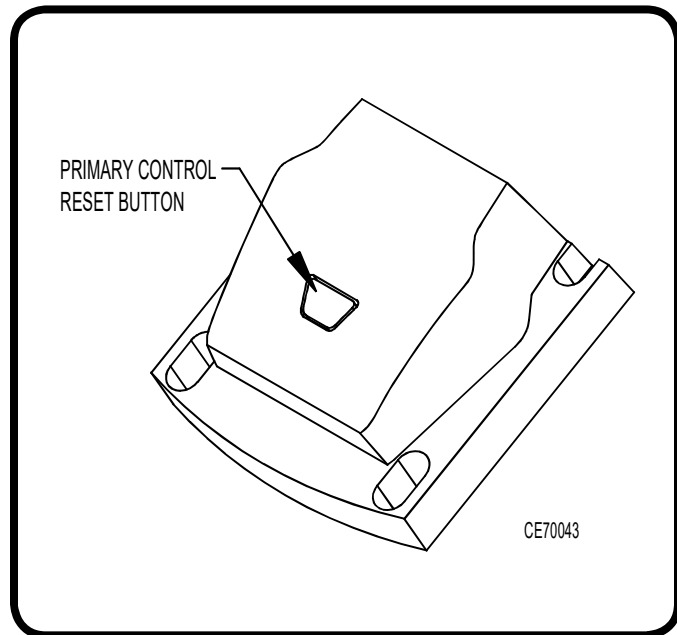

Figure 26: Oil Primary Control Reset Button

SETTING THE DRAFT



WARNING: Do not operate your furnace if a proper draft is not obtained or damage to critical burner components will occur.

- (1) Allow the furnace to run for 5 to 10 minutes.
- (2) Refer to Figure 27 to locate the draft gauge hole.
- (3) Insert a draft gauge through the hole in the observation port. Follow the manufacturer's instructions for adjusting the barometric damper to obtain -0.02 " w.c. draft over fire.
- (4) If a proper draft is not obtained, follow the instructions below to check for a vacuum in your building.

Checking for vacuum in your building:

- (1) Have someone slowly open an overhead door while you are taking a draft reading.
- (2) Watch the draft gauge and tell them to stop when you get a -0.02 " w.c. draft over fire.
- (3) Measure the opening created by the overhead door. This is the opening size you need for make up air to allow the furnace to draft properly.

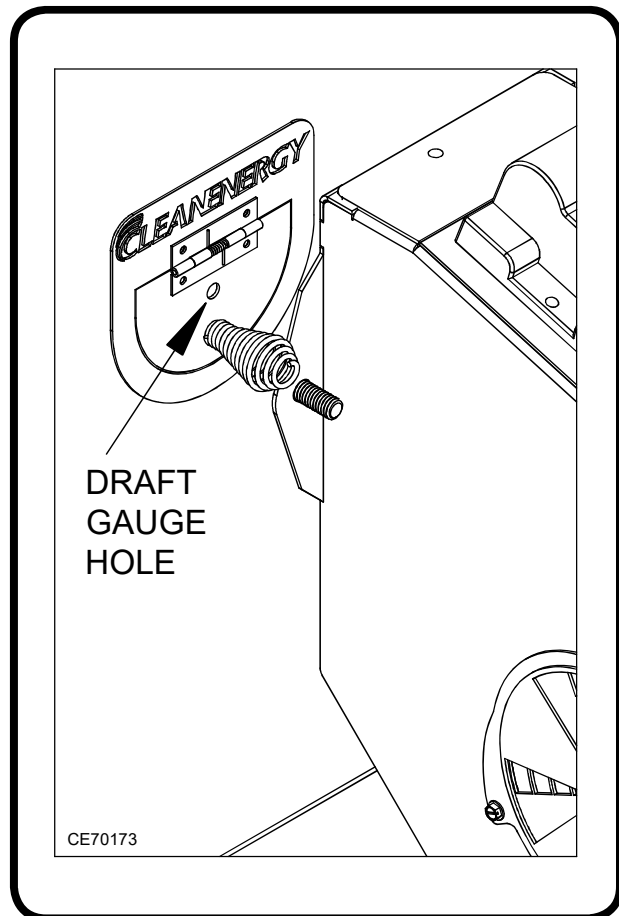

Figure 27: Draft Gauge Hole in the Observation Port

MAINTENANCE

Periodic Maintenance Schedule:

- (1) Clean the oil filter and pump head screen.....once a year
- (2) Clean sludge and water from the tank.....once a year
- (3) Clean ash from the heat exchanger.....1200 hours
- (4) Flush the nozzle adapter heater block.....2000 to 3000 hours

Cleaning the oil canister filter screen:

- (1) Place a container under the canister filter to catch any released oil.
- (2) Use a 3/16" allen wrench to loosen the canister.
- (3) Drop the canister down and remove the filter screen.
- (4) Thoroughly clean the filter screen in a parts washer.
- (5) Fill the canister 3/4 full with used oil (this will aid in pump priming) and slowly insert the filter screen back into the canister.
- (6) Tighten the 4 socket head screws in a crisscross pattern.

NOTICE: Do not over-tighten or the aluminum filter casting may crack.

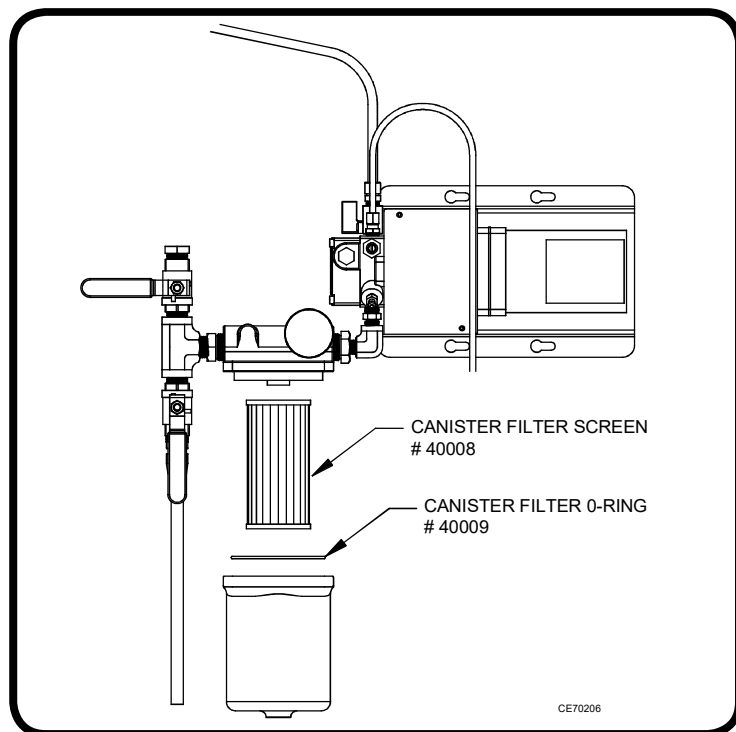

Figure 28: Removing the Oil Canister Filter Screen

Cleaning the oil pump head screen:

- (1) Place a container under the oil pump head to catch any released oil.
- (2) Use a 5/32" allen wrench to loosen the pump head cover.
- (3) Remove the cover, pump head screen and gasket. Carefully scrape the gasket off if any pieces remain stuck to the pump head.
- (4) Thoroughly clean the pump head screen in a parts washer.
- (5) Install a new pump head gasket and put the cleaned screen in place.
- (6) Tighten the 4 socket head screws in a crisscross pattern.

NOTICE: Do not over tighten or the aluminum pump head cover may crack.

- (7) Once the filter and pump head screen are clean, follow instructions in the "Priming the Metering Pump" section.

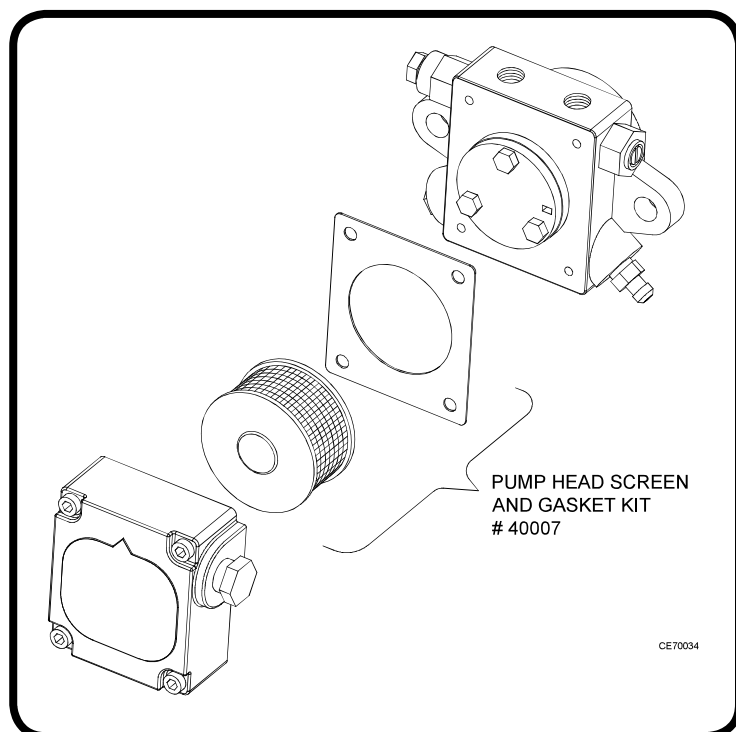

Figure 29: Removing the Oil Pump Head Screen

MAINTENANCE

Cleaning sludge and water from the bottom of the tank:

NOTICE: Because of the nature of used oil handling practices, it is very difficult to keep all water and sludge out of the used oil supply. Drain the used oil supply tank at least once a year to ensure no unwanted substance is being delivered to the furnace.

- (1) Connect a tube to the drain on the bottom of the tank and collect a sampling in a drain pan or bucket. Keep draining the tank until all water and sludge has been removed.
- (2) If there is no drain on your supply tank insert a transfer pump with the suction line inserted down to the bottom of the tank. Keep pumping out the tank until all sludge and water has been removed.

Cleaning ash from the heat exchanger:



CAUTION: Wear safety goggles, gloves, long sleeves and a dust mask when cleaning ash from the furnace. The accumulated ash is in the form of a fine powder and may cause irritation.



CAUTION: DO NOT attempt to clean ash from a hot furnace. It is a burn hazard as well as a fire hazard when the hot ashes are disposed of.

- (1) Refer to Figure 30.
- (2) Turn OFF power to the furnace and disconnect the power cord from the top of the burner.
- (3) Release the two over-center latches on the left side of the front door.
- (4) Carefully open the front clean out door.
- (5) Use a long broom handle or rod to reach to the back and gently remove the combustion chamber target.
- (6) Brush out the combustion chamber and use an industrial vacuum to clean out the remaining ash.
- (7) Release the four over-center latches on the top clean out door. Carefully swing the top clean out door open.
- (8) Use a 3" flue brush to completely remove ash from the flue tubes.
- (9) Use an industrial vacuum to clean out the top header.
- (10) Remove the 6" round cap opposite the chimney connection. Remove the chimney if there is no access to the 6" round cap. Use an industrial vacuum to clean the bottom header.
- (11) Fasten all clean out doors and chimney components.

MAINTENANCE

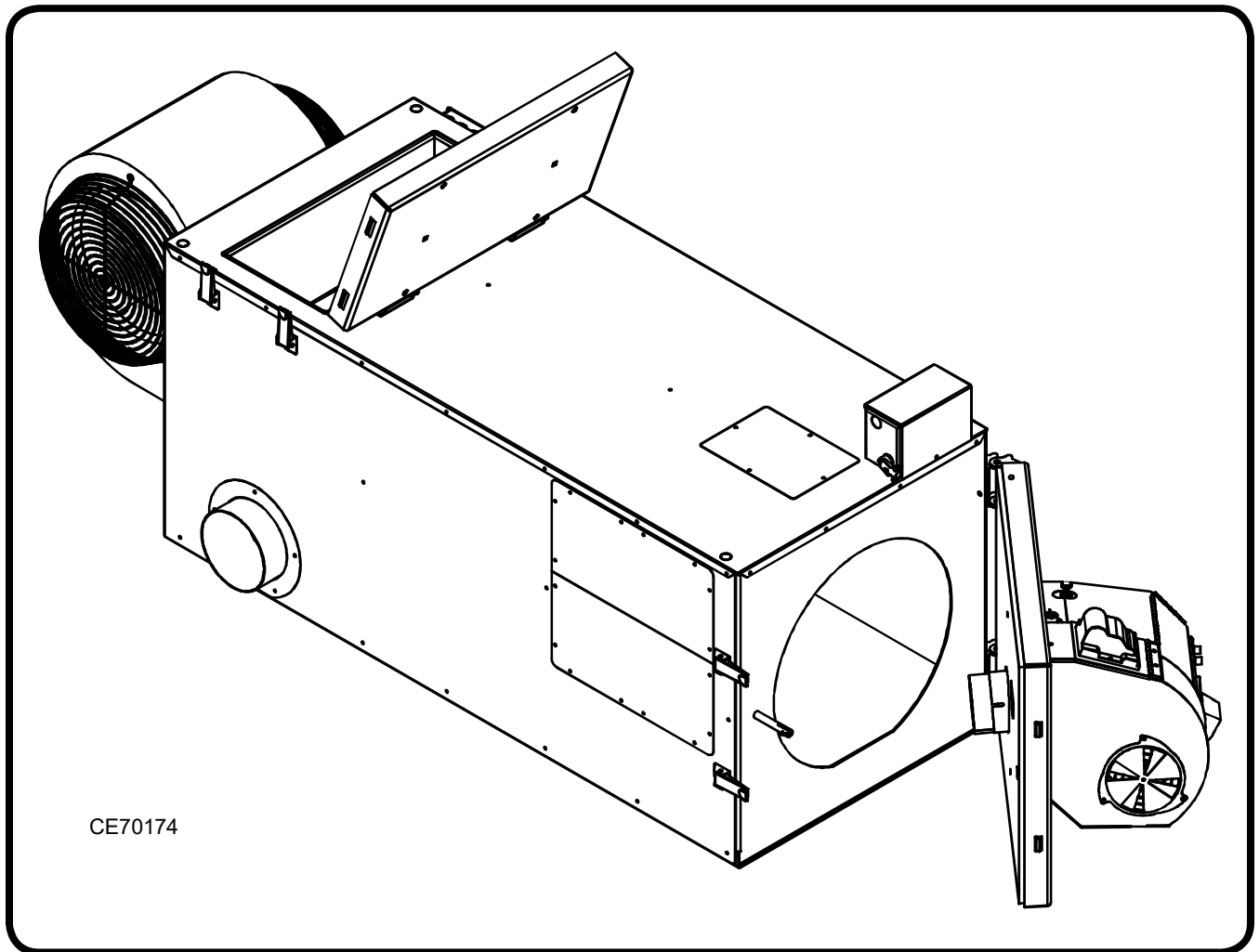
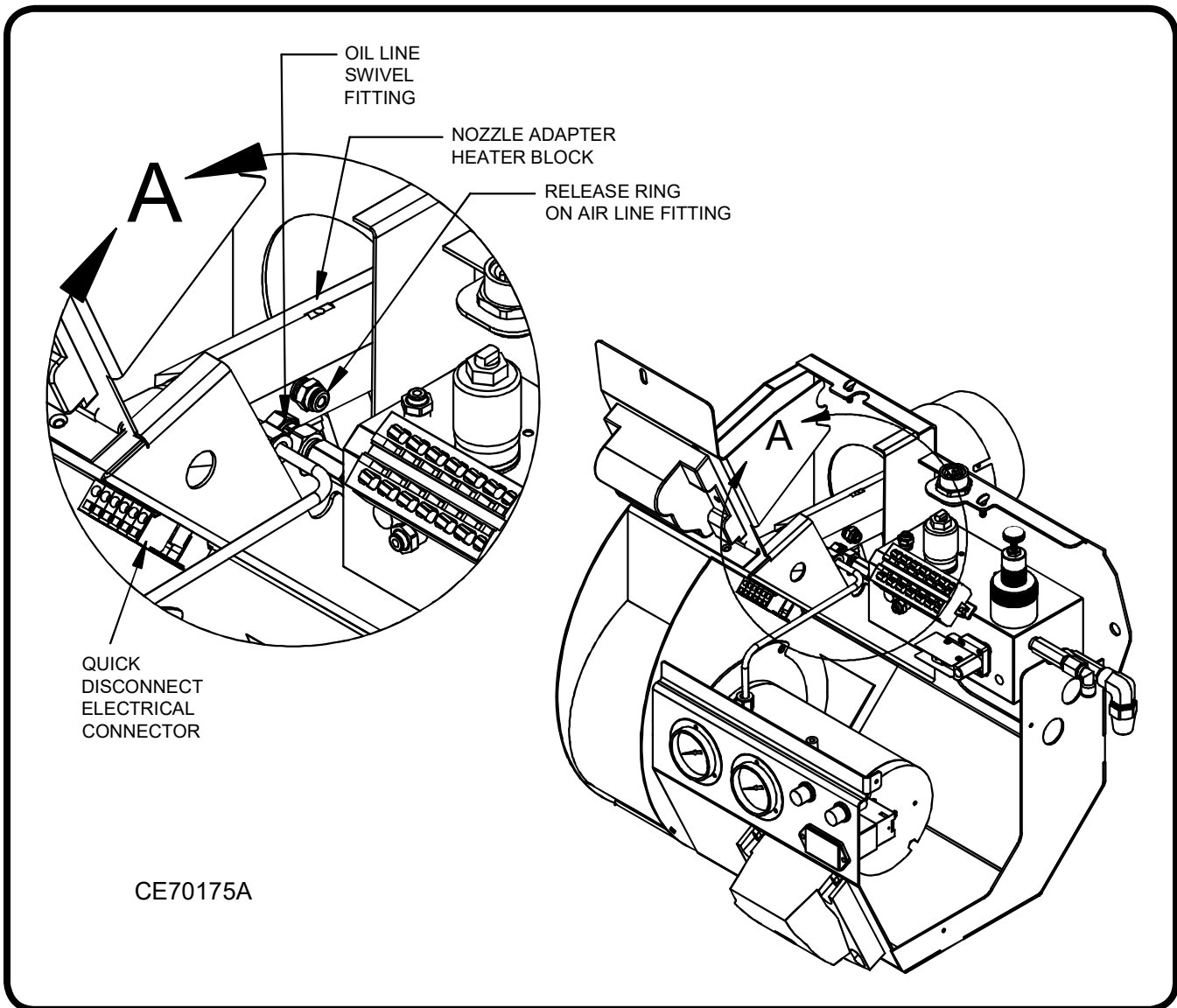

Figure 30: Cleaning Ash From the Heat Exchanger

Flush the nozzle adapter heater block:

- (1) Refer to Figure 31.
- (2) Open the igniter hinge cover on the burner.
- (3) Remove the electrode
- (4) Loosen the oil line swivel fitting with a 9/16" open end wrench.
- (5) Disconnect the air line by pushing on the release ring and pulling the tube out of the fitting.
- (6) Disconnect the quick disconnect electrical connector.
- (7) Disconnect the 3/16" copper tubing for the oil gauge.
- (8) Carefully remove the entire aluminum nozzle adapter heater block from the burner.
- (9) Remove all the components from the nozzle adapter heater block.
- (10) Remove all the plugs from the oil ports with a 5/32" allen wrench.
- (11) Clean the nozzle adapter heater block in a parts washer. A tube cleaning wire brush (rifle barrel cleaning brush) can be used to properly clean the oil ports.
- (12) Blow out all passages with a compressed air blowgun.
- (13) Put all the plugs and components back on the nozzle adapter heater block and re-install it in the burner.

MAINTENANCE



Nozzle adapter heater block with all components and plugs removed.

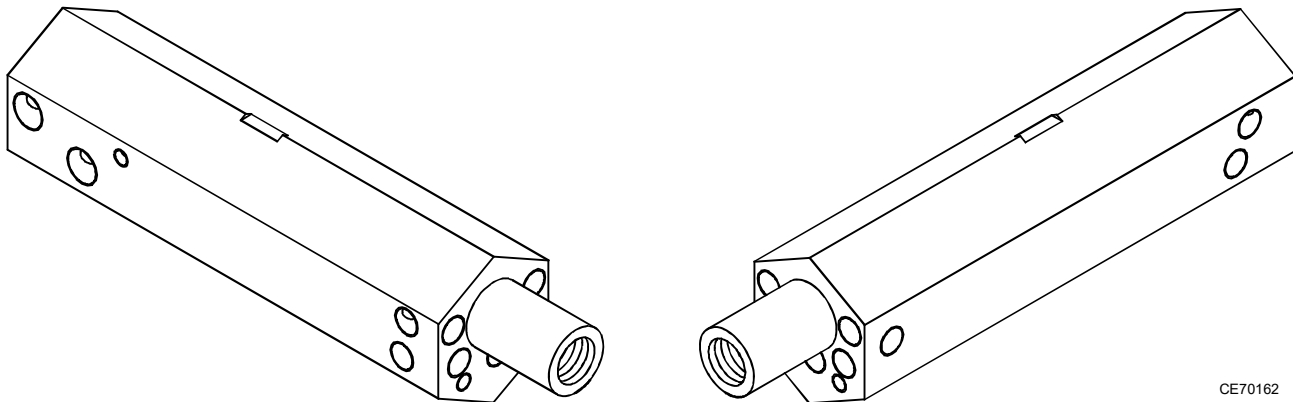
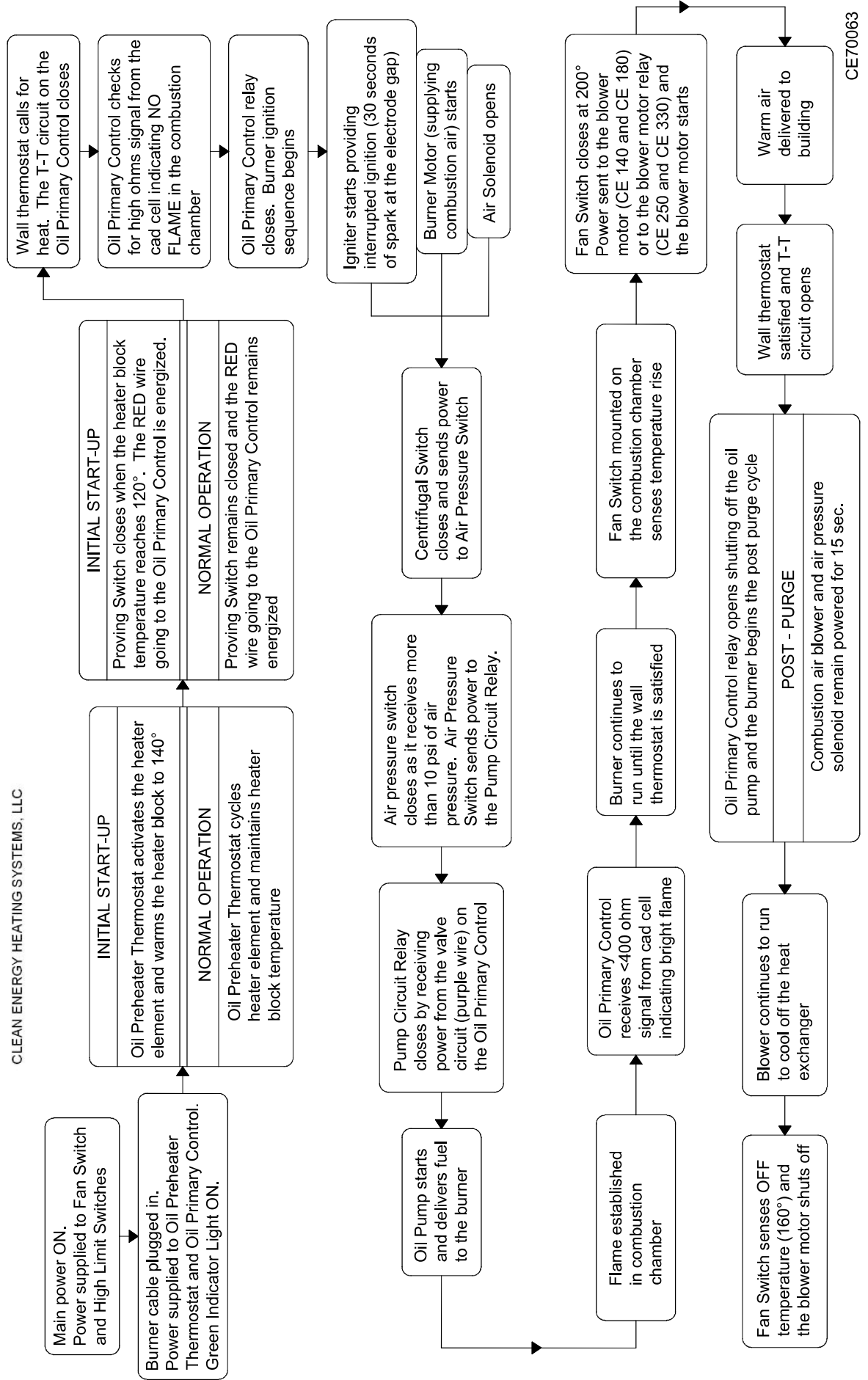

Figure 31: Flushing the Nozzle Adapter Heater Block



CLEAN ENERGY HEATING SYSTEMS, LLC

SEQUENCE OF OPERATION



CE70063

Clean Energy Heating Systems Troubleshooting Sequence

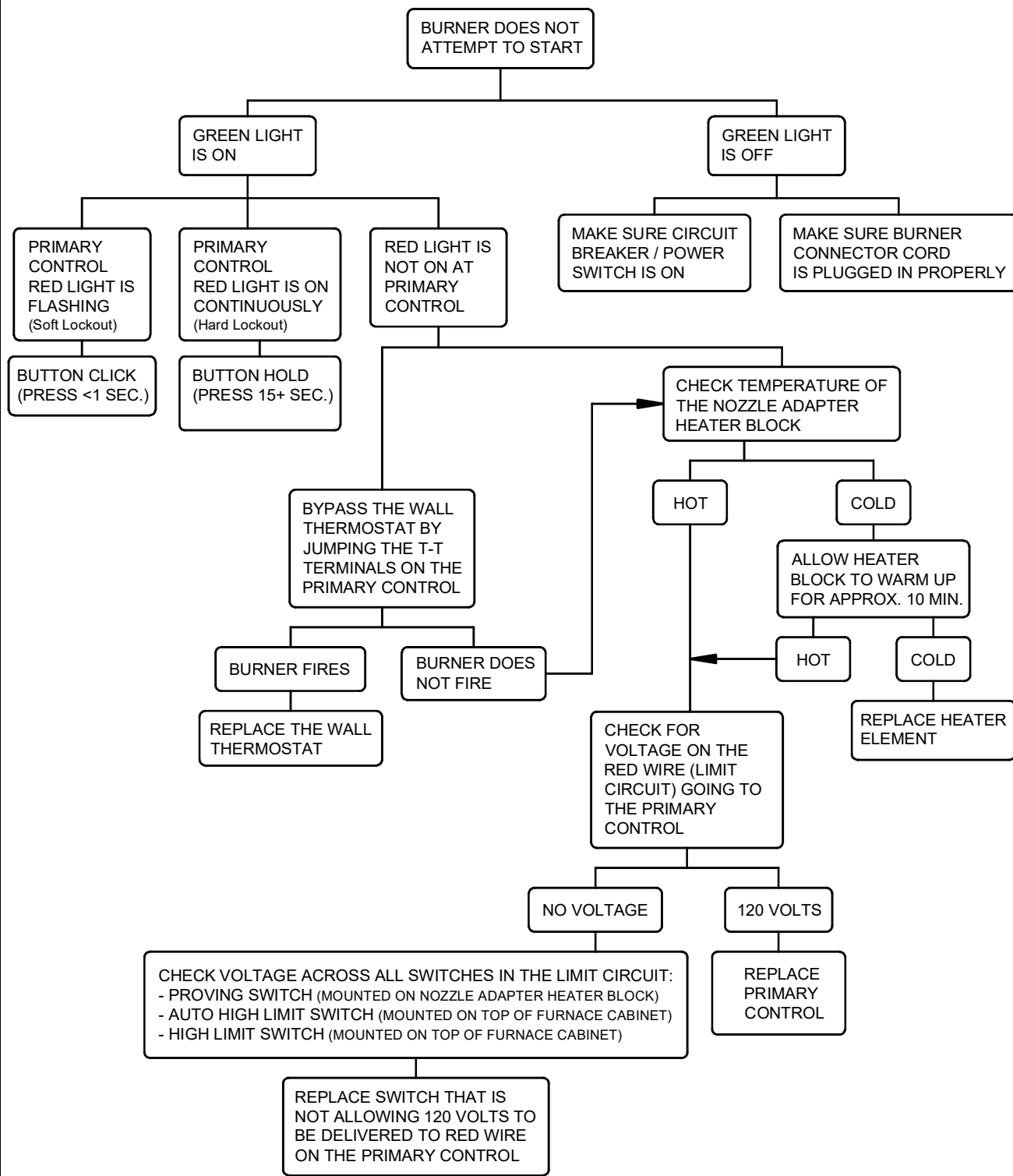

CE70151

Clean Energy Heating Systems Troubleshooting Sequence

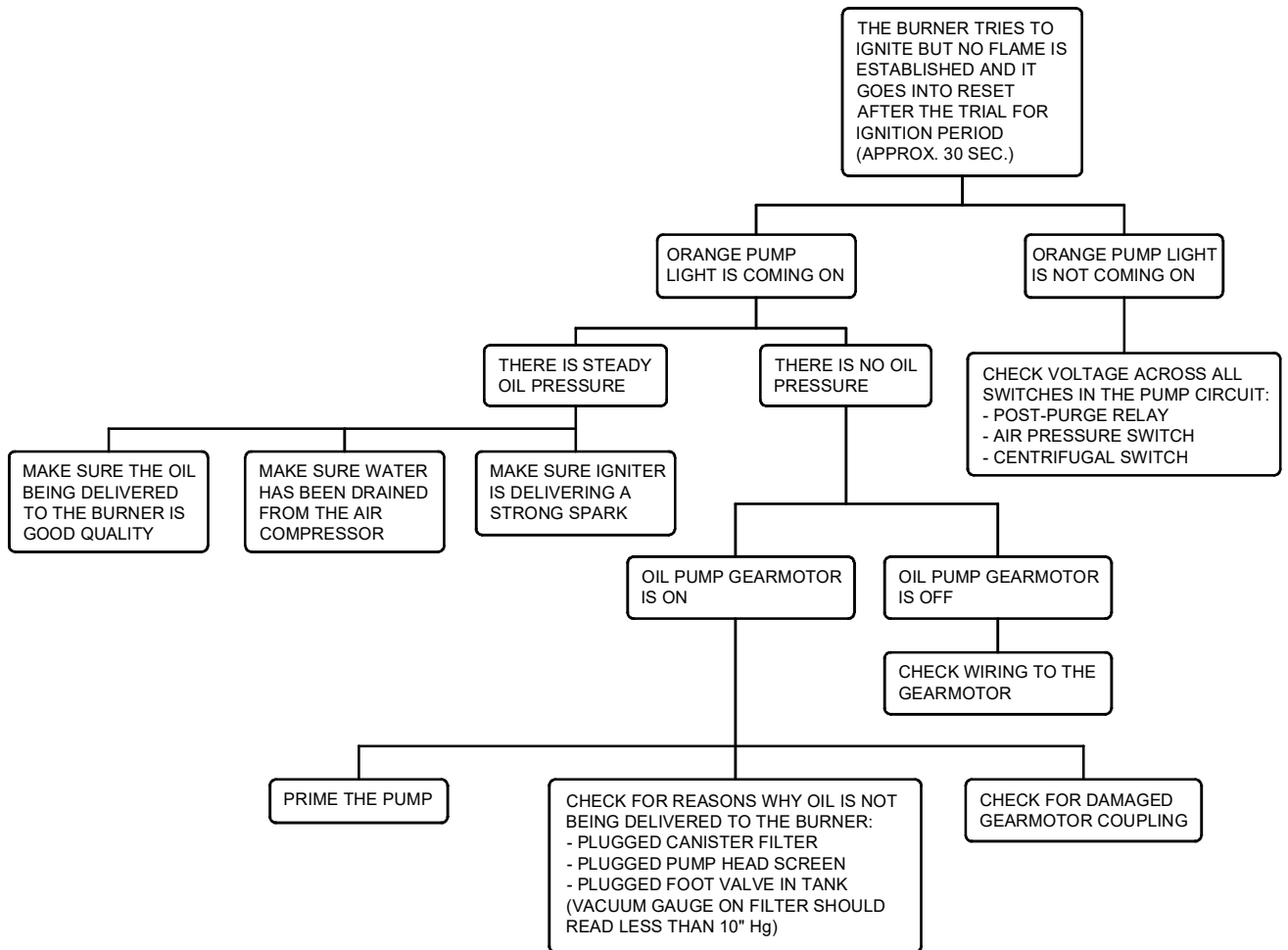
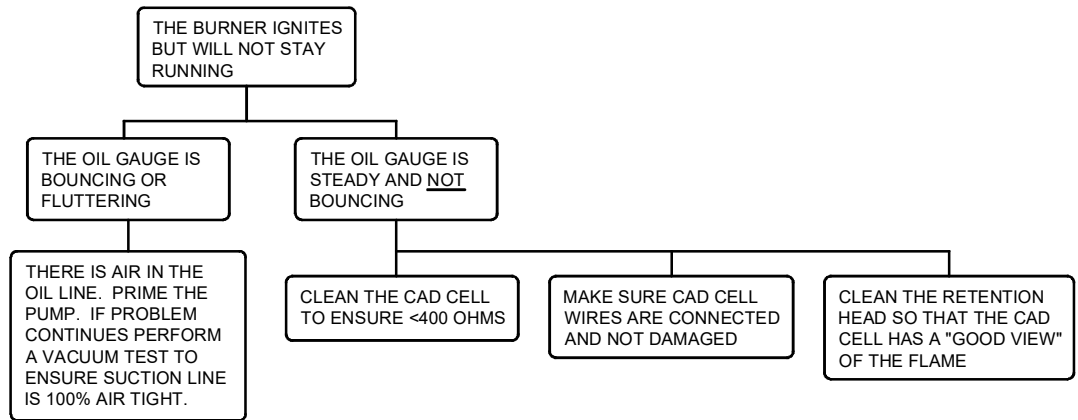

CE70152

FURNACE DIMENSIONS

CE 140

- 6" Chimney Pipe Diameter
- Threaded Rod Knock Outs
44-5/8" X 21-3/8"
- Louver Opening
13-1/2" SQ.

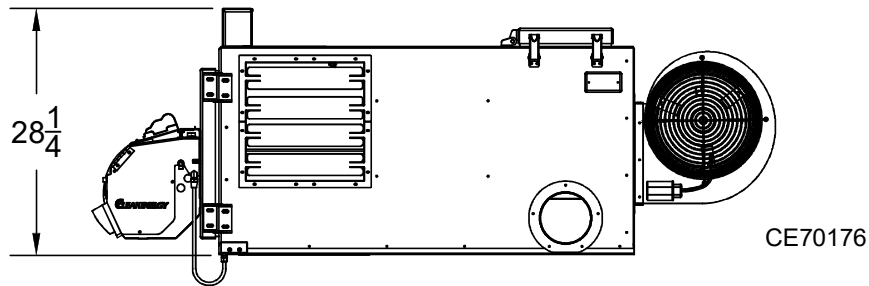
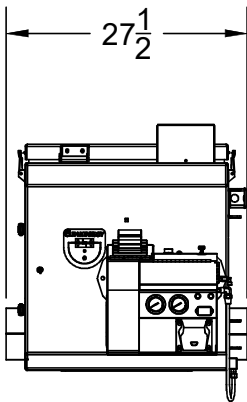
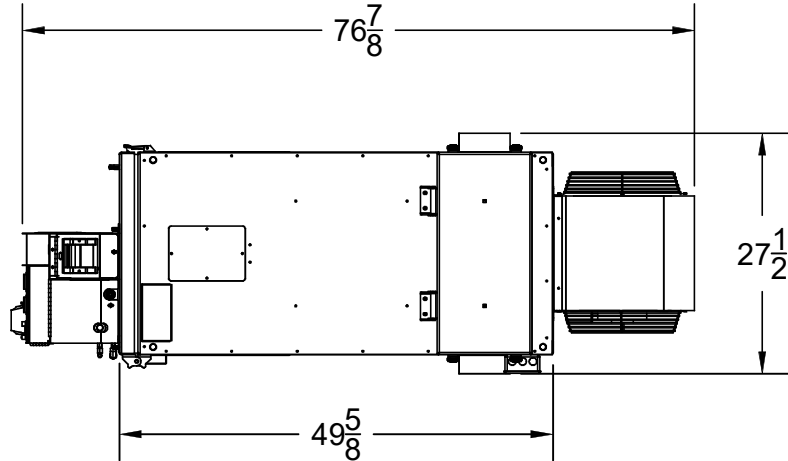

CE 180

- 6" Chimney Pipe Diameter
- Threaded Rod Knock Outs
50-3/8" X 21-3/8"
- Louver Opening
13-1/2" SQ.

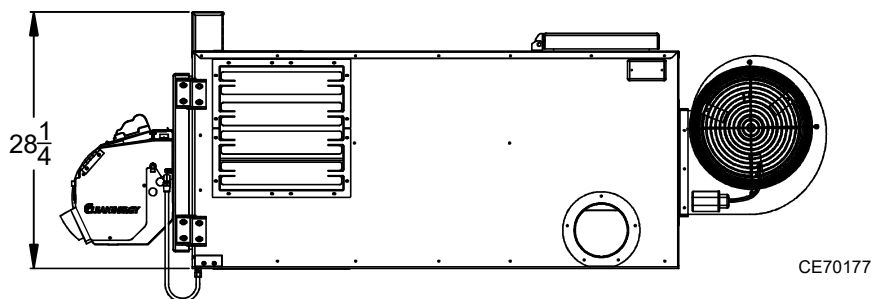
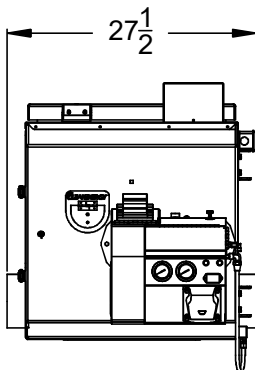
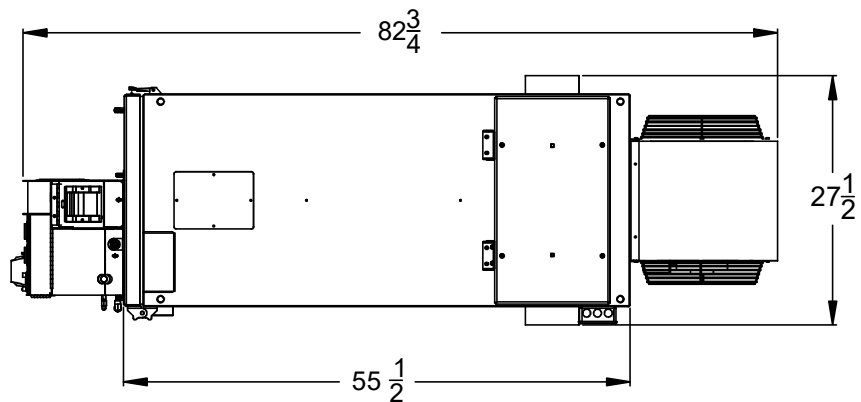

FURNACE DIMENSIONS

CE 250

- 6" Chimney Pipe Diameter
- Threaded Rod Knock Outs
63-5/8" X 21-3/8"
- Louver Opening
13-1/2" SQ.

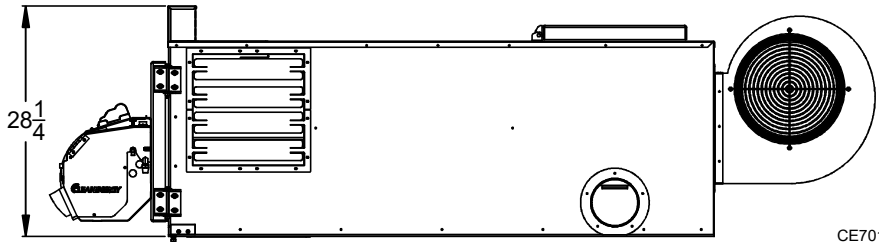
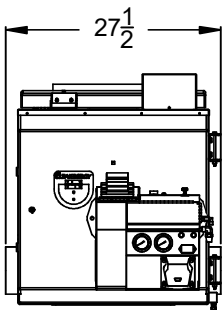
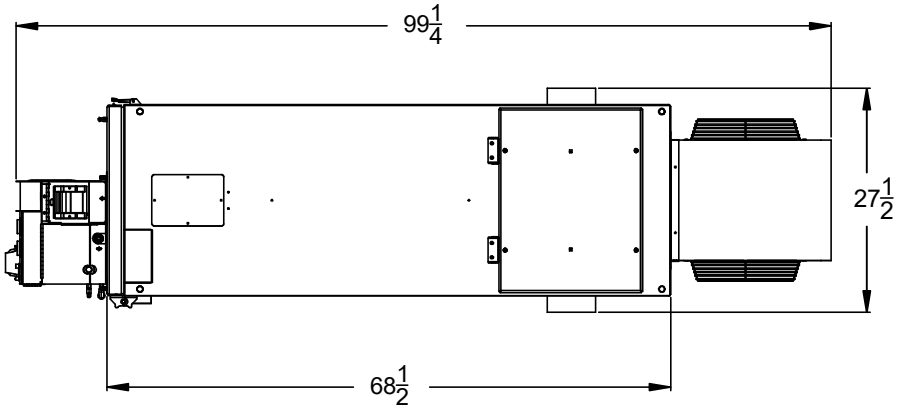

CE70178

CE 330

- 8" Chimney Pipe Diameter
- Threaded Rod Knock Outs
68-5/8" X 21-3/8"
- Louver Opening
15-1/2" SQ.

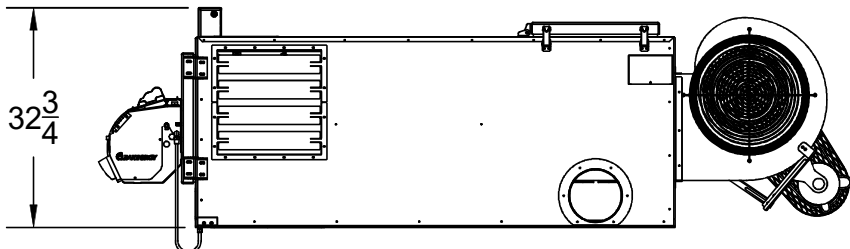
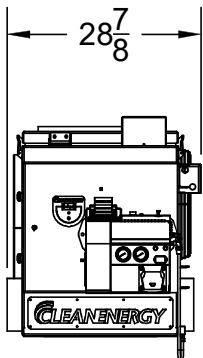
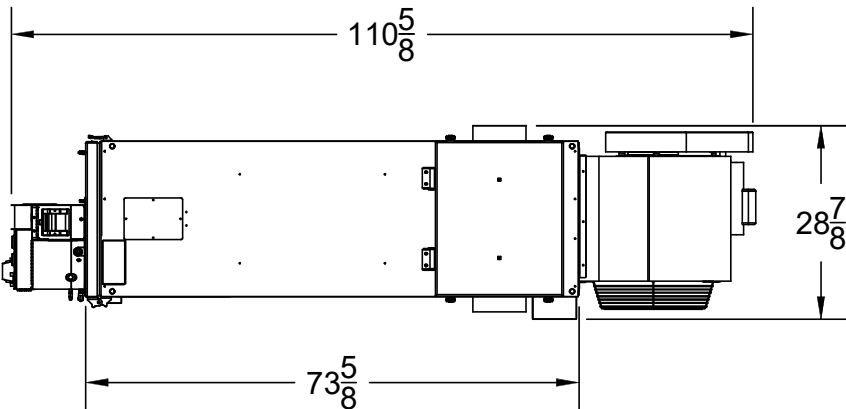

CE70179

FURNACE DIMENSIONS

CE 440

- 8" Chimney Pipe Diameter
- Threaded Rod Knock Outs
79-1/2" X 25-1/2"
- Louver Opening
17-1/2" SQ

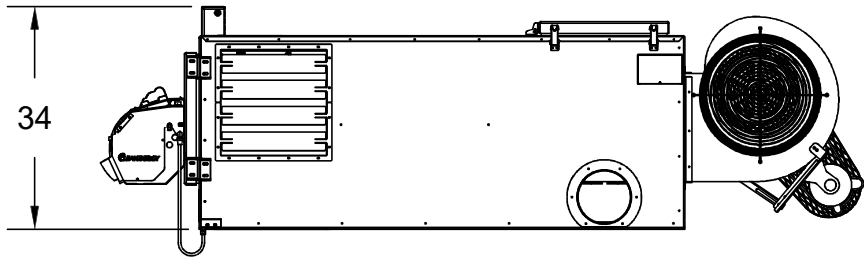
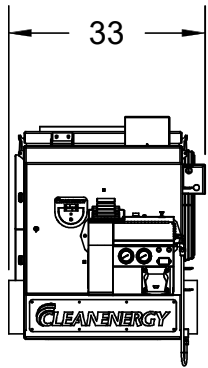
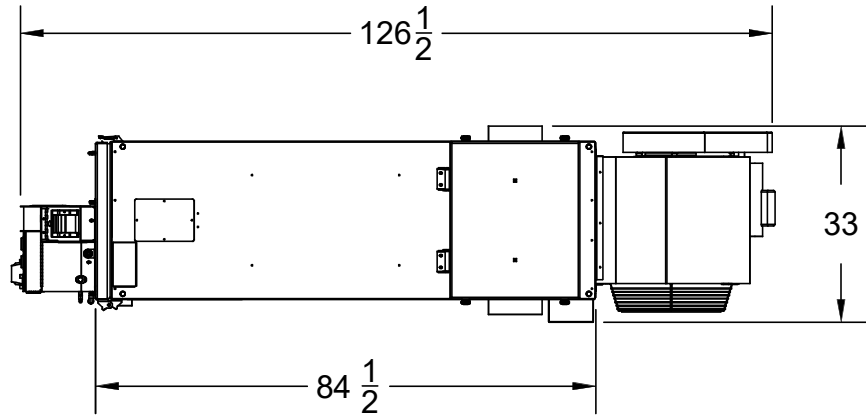

CE70210

WIRE DIAGRAMS

CE-140 AND CE-180 FURNACE CABINET WIRE DIAGRAM:

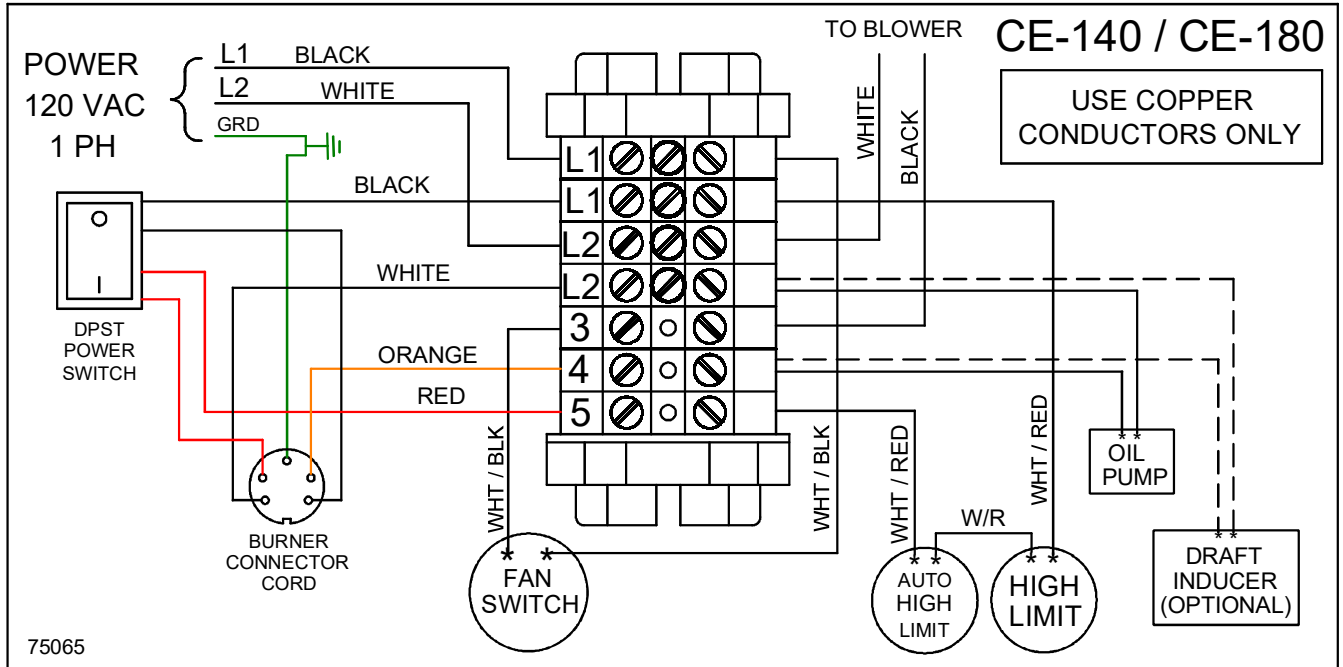

CE-140 AND CE-180 BLOWER WIRE DIAGRAM:

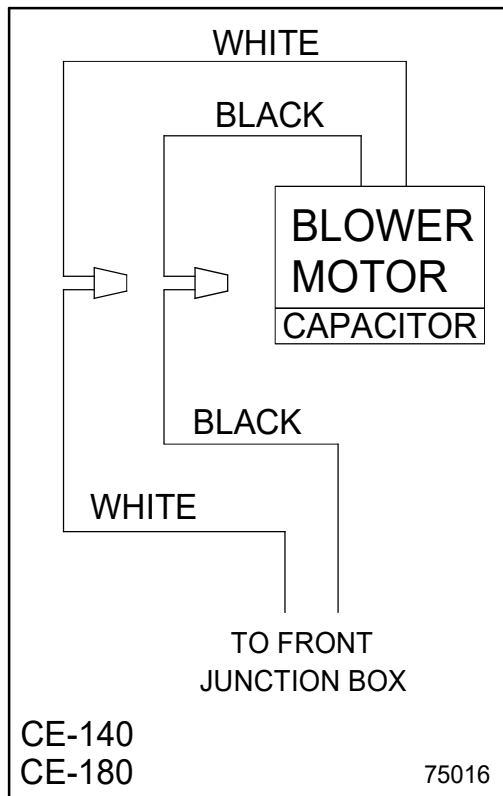

WIRE DIAGRAMS

CE-250 FURNACE CABINET WIRE DIAGRAM:

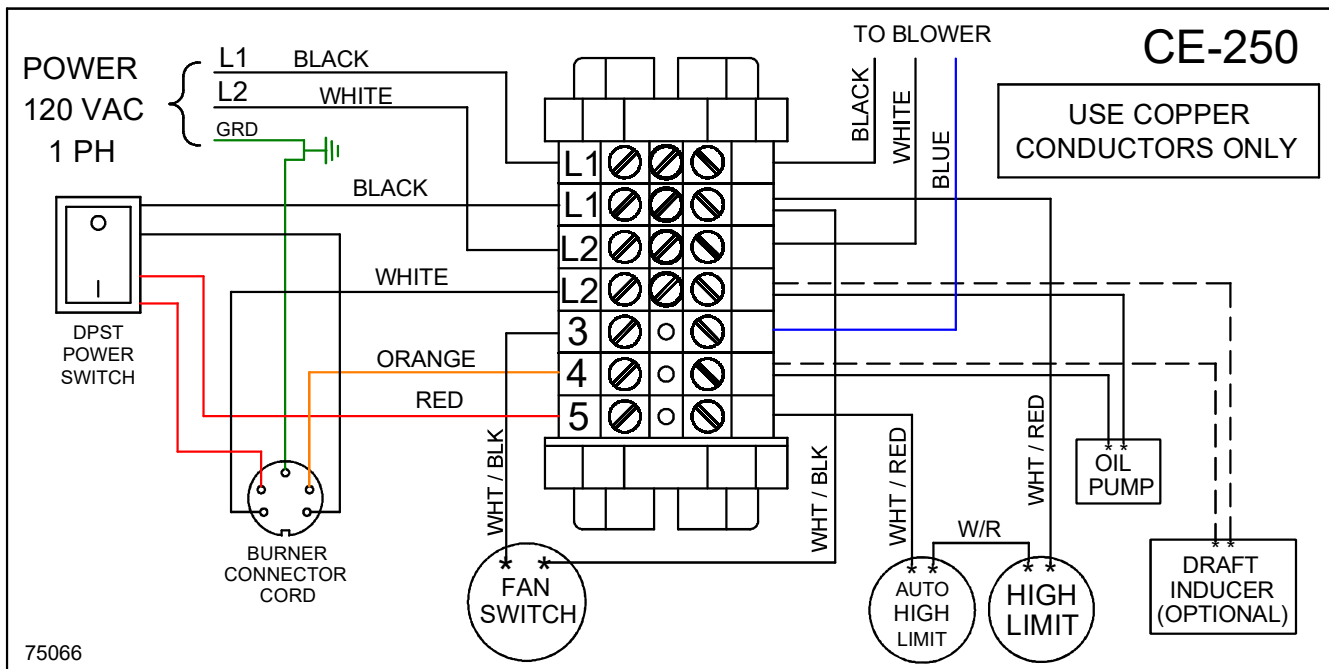

CE-250 BLOWER WIRE DIAGRAM:

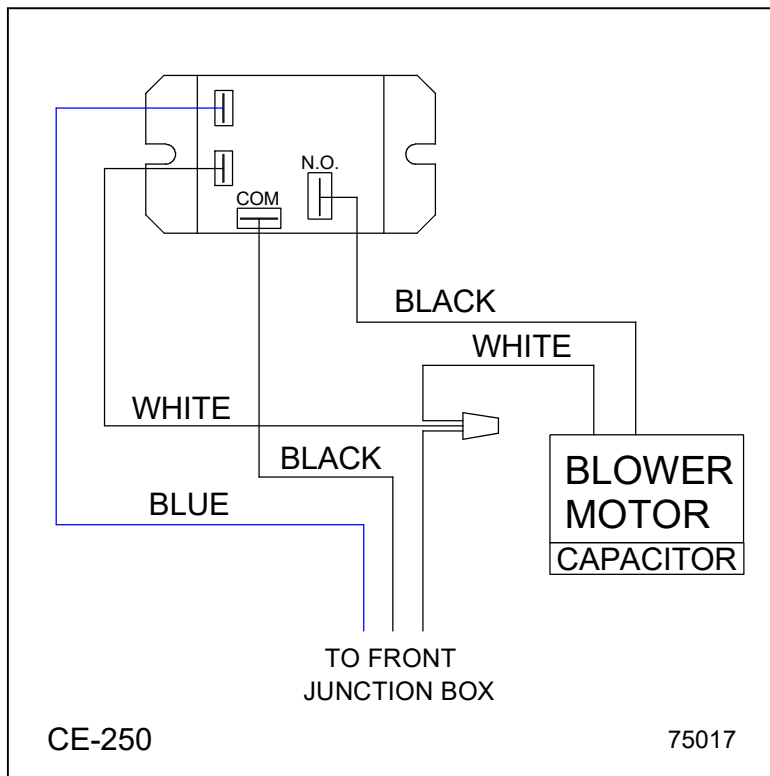

WIRE DIAGRAMS

CE-3 BURNER WIRE DIAGRAM (USED ON CE-140, CE-180, AND CE-250):

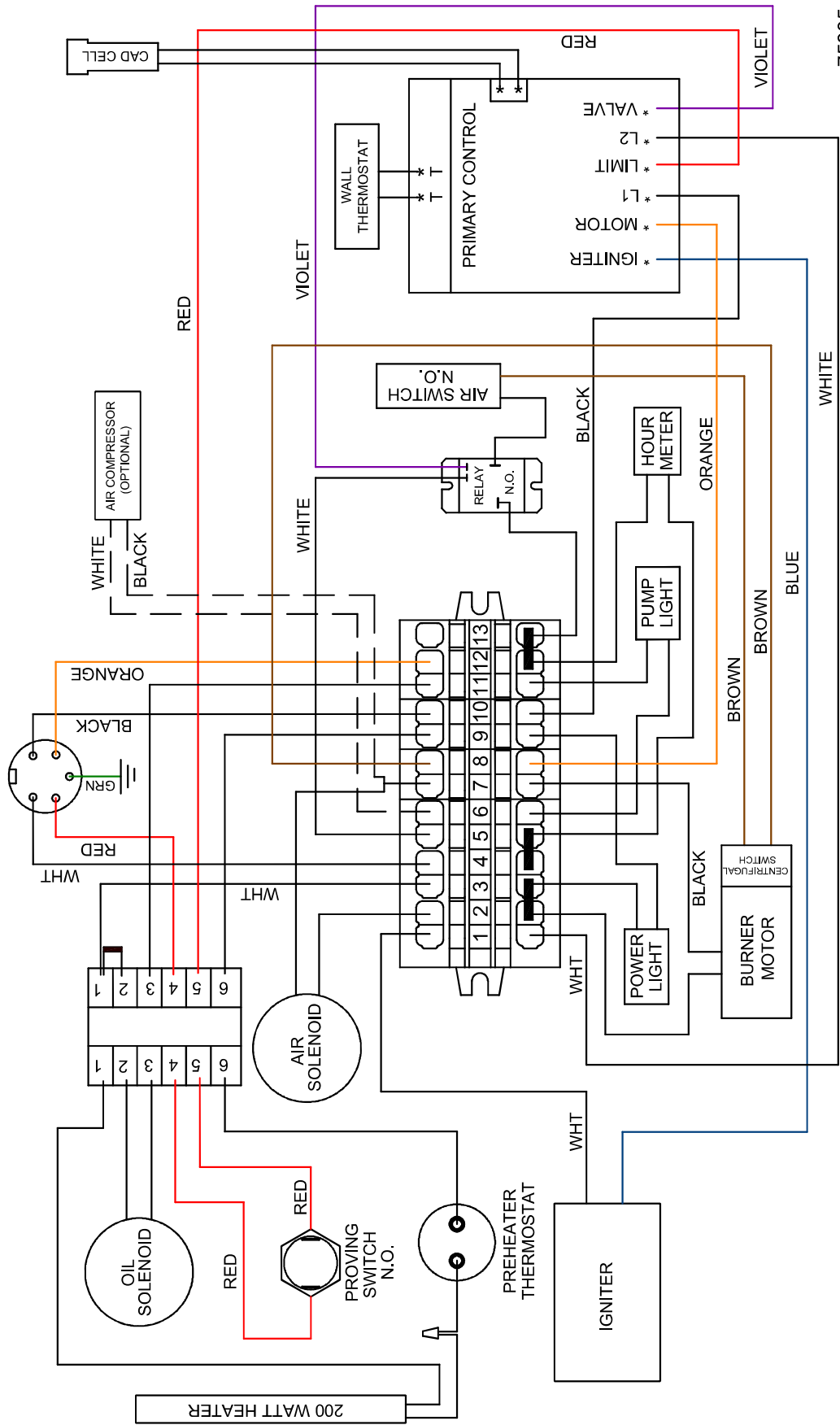

75005

WIRE DIAGRAMS

CE-4 BURNER WIRE DIAGRAM (USED ON CE-330 and CE-440):

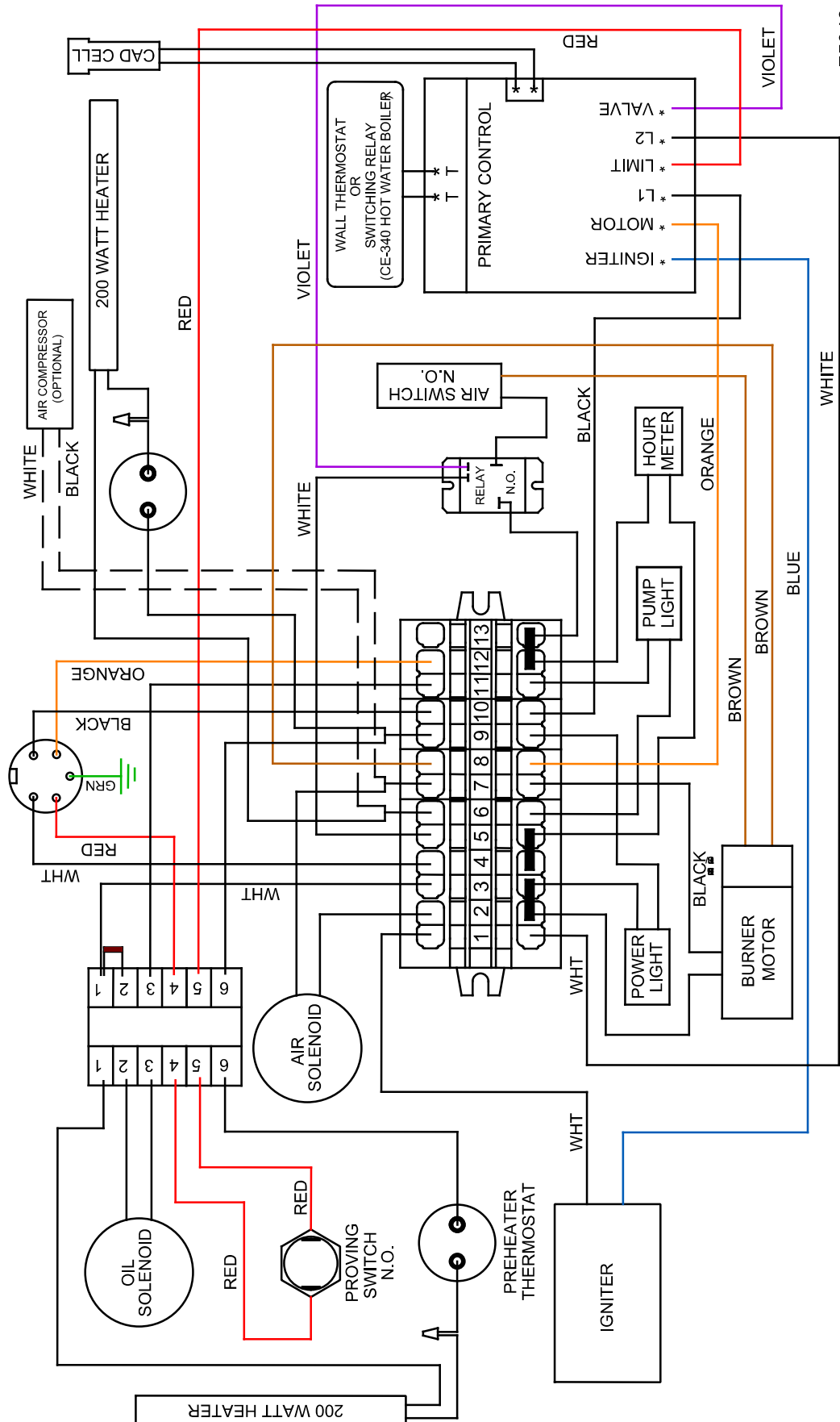

75043

WIRE DIAGRAMS

METERING PUMP GEARMOTOR WIRE DIAGRAM:

Bison Gearmotor:

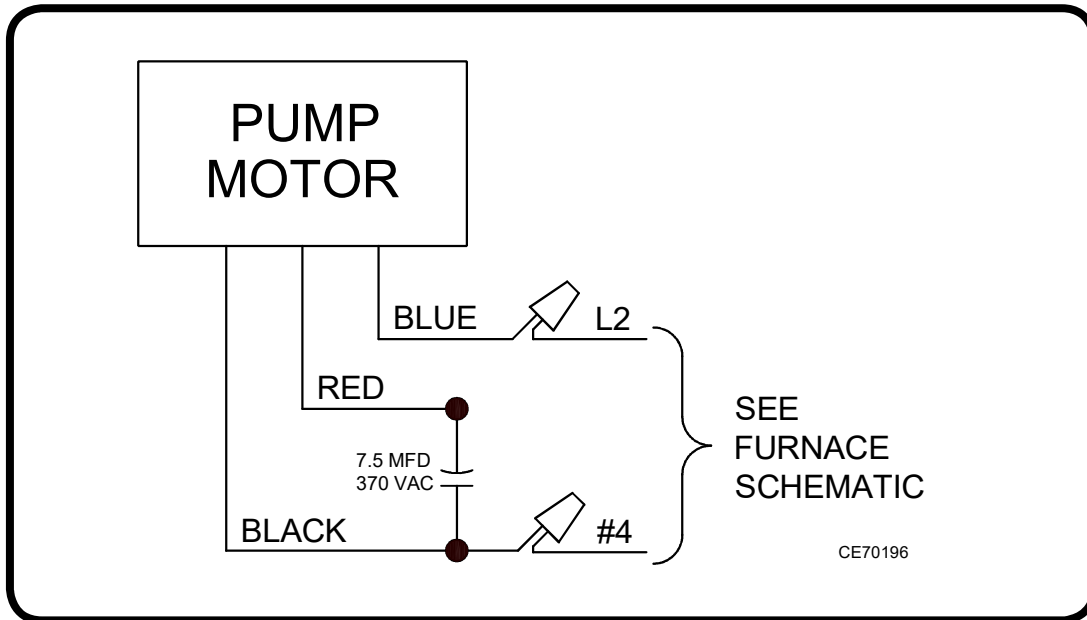

Bodine Gearmotor:

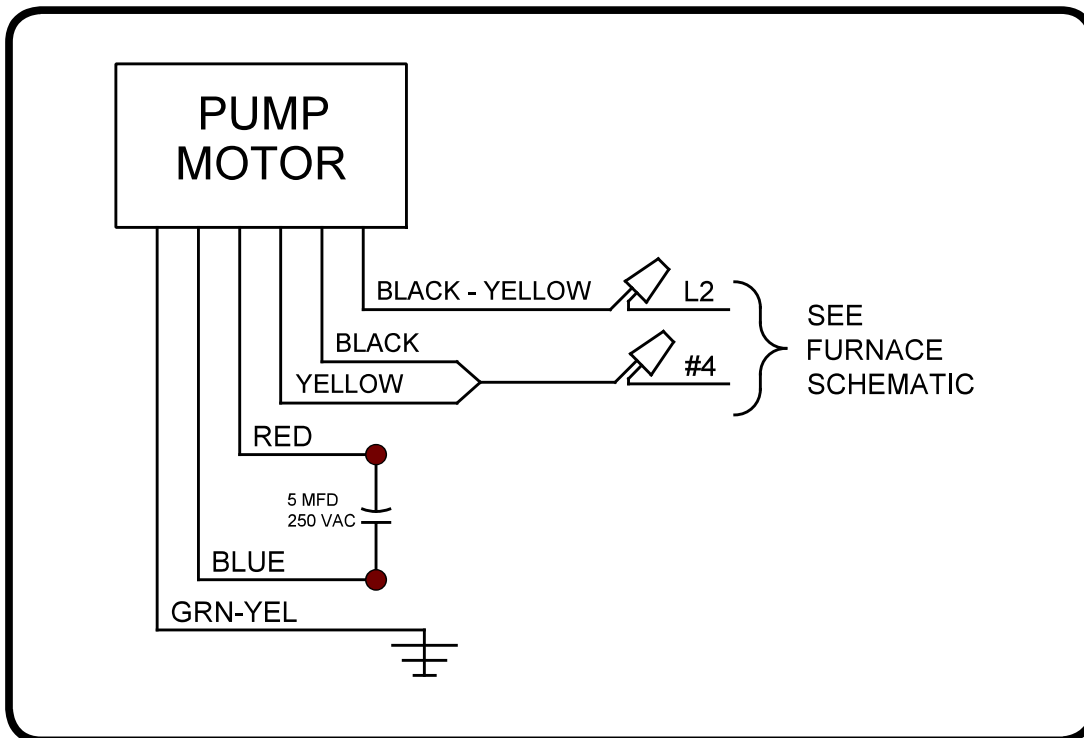

BURNER POWER SWITCH

Review the figure below along with the wire diagram for your furnace model for additional information about the Burner power Switch. Power to the burner must be shut off prior to disconnecting or connecting the Burner Connector Cord.

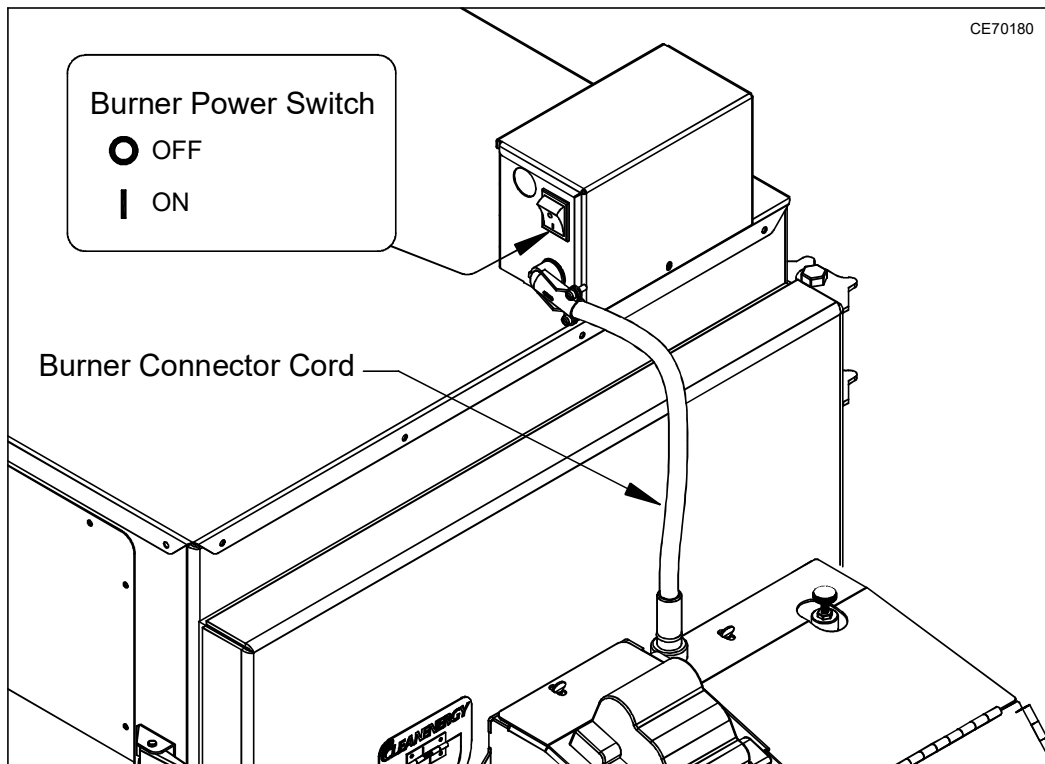

Burner Power Switch Location

ITEM	PART #	DESCRIPTION	QTY.
	60301	CE-3 EZ Burner Assembly	
	60401	CE-4 EZ Burner Assembly	
1	65030	Burner Housing Top Cover	1
2	65029	Ignitor Hinge Plate	1
3	30025	Burner Receptacle (5-Wire)	1
4	58045	Machine Screw 10-32 x 7/8	1
5	58040	Washer Neoprene Bonded #10 - 1/2 OD	1
6	30001	Electrode	1
7	65041	Retention Head	1
8	60020	Nozzle Adapter Heater Block Assembly	1
9	58014	HHCS 1/4 -20 x 1/2	2
10	65028	Burner Housing	1
11	50008	Burner Manifold Block	1
12	50065	1/8 MP X 2 HEX NIPPLE	2
13	50056	1/4 TUBE x 1/8 FNPT 90°	1
14	50059	3/8 Compression x 1/8 FNPT 90°	1
15	30057	Plug - push in 7/8" hole	2
16	50051	3/8" Compression Ferrule	1
17	50052	3/8" Compression Nut	1
18	58023	Flange Serrated Nut 10-24 Z	3
19	20236	Right Side Cover	1
20	30017	Burner Blower Motor	1
21	20034	Motor Mount Plate	1
22	58024	Lock Nut 8-32 Nylon Z	4
23	50015	Squirrel Cage - Burner	1
24	30009	Relay SPST	1
25	30016	Hour Meter	1
26	30033	Green Light	1
27	30034	Amber Light	1
28	50019	Primary Control	1
29	50085	Tubing - Air Line (1/8" OD)	10"
30	50061	1/8 Tube - 1/8 FP x 90o	1
31	20025	Gauge Mount	1
32	50017	Air Pressure Gauge	1
33	50016	Oil Pressure Gauge	1
34	50060	3/16 Compression x 1/8 FNPT 90°	1
35	50058	3/16 Compression Ferrule	1
36	50057	3/16 Compression Nut	1
37	30026	Terminal Block Quick Disconnect - Male	1
38	30038	Terminal Block Quick Disconnect - Female	1
39	20153	Copper Tube 3/16 oil gauge	1
40	58035	Lock Washer #8	1
41	58033	Cap Screw Socket Head 10-24 x 3/8 SS	1
42	20037	Air Intake - Outer Plate	1
43	65006	Air Intake - Inner Plate	1
44	30022	CAD CELL	1
45	30027	Post Contact - Igniter	2
46	50020	Igniter	1

NOZZLE ADAPTER / HEATER BLOCK ASSEMBLY

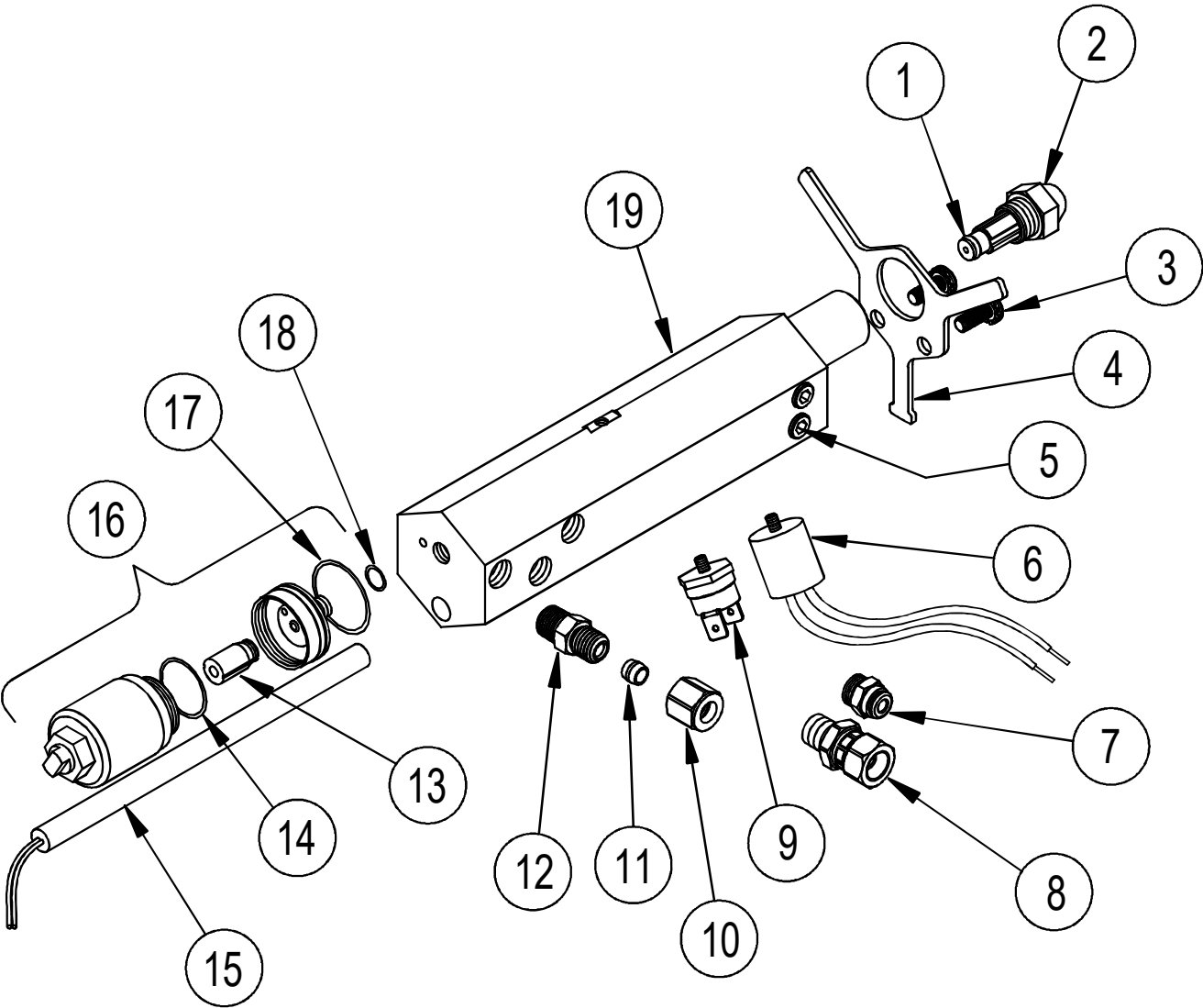

ITEM	PART #	DESCRIPTION	QTY.
	60020	Nozzle Adapter Heater Block Assembly	
1	50250	O-ring Nozzle	1
2	40005	Nozzle 9-5 (Used in CE-3 EZ Burner on Model CE-140 / CE-180 / CE-250)	1
2	40018	Nozzle 9-8 (Used in CE-4 EZ Burner on Model CE-330 / CE-340 / CE-440)	1
3	58054	Machine Screw 10-32 x 3/8 Z Ext Tooth LW	2
4	20008	Nozzle Adaptor Bracket - Three Legs	1
5	50067	Plug - Hex Socket	10
6	30011	Thermostat 150F - Heater	1
7	50364	Tube Fitting, 5/32 Tube X 1/8 MNPT	1
8	50024	Swivel Fitting	1
9	30003	Thermostat 120F - Proving Switch	1
10	50057	3/16 Compression Nut	1
11	50058	3/16 Compression Ferrule	1
12	50066	3/16 Compression x 1/8 MNPT	1
13	50256	Plunger - Air/Oil Solenoid	1
14	50253	O-Ring Solenoid Inner	1
15	30002	Heat Element	1
16	50022	Solenoid Air/Oil 115VAC	1
17	50255	O-Ring Solenoid Large	1
18	50254	O-Ring Solenoid Small	1
19	50009	Nozzle Adapter / Heater Block	1

MANIFOLD BLOCK ASSEMBLY

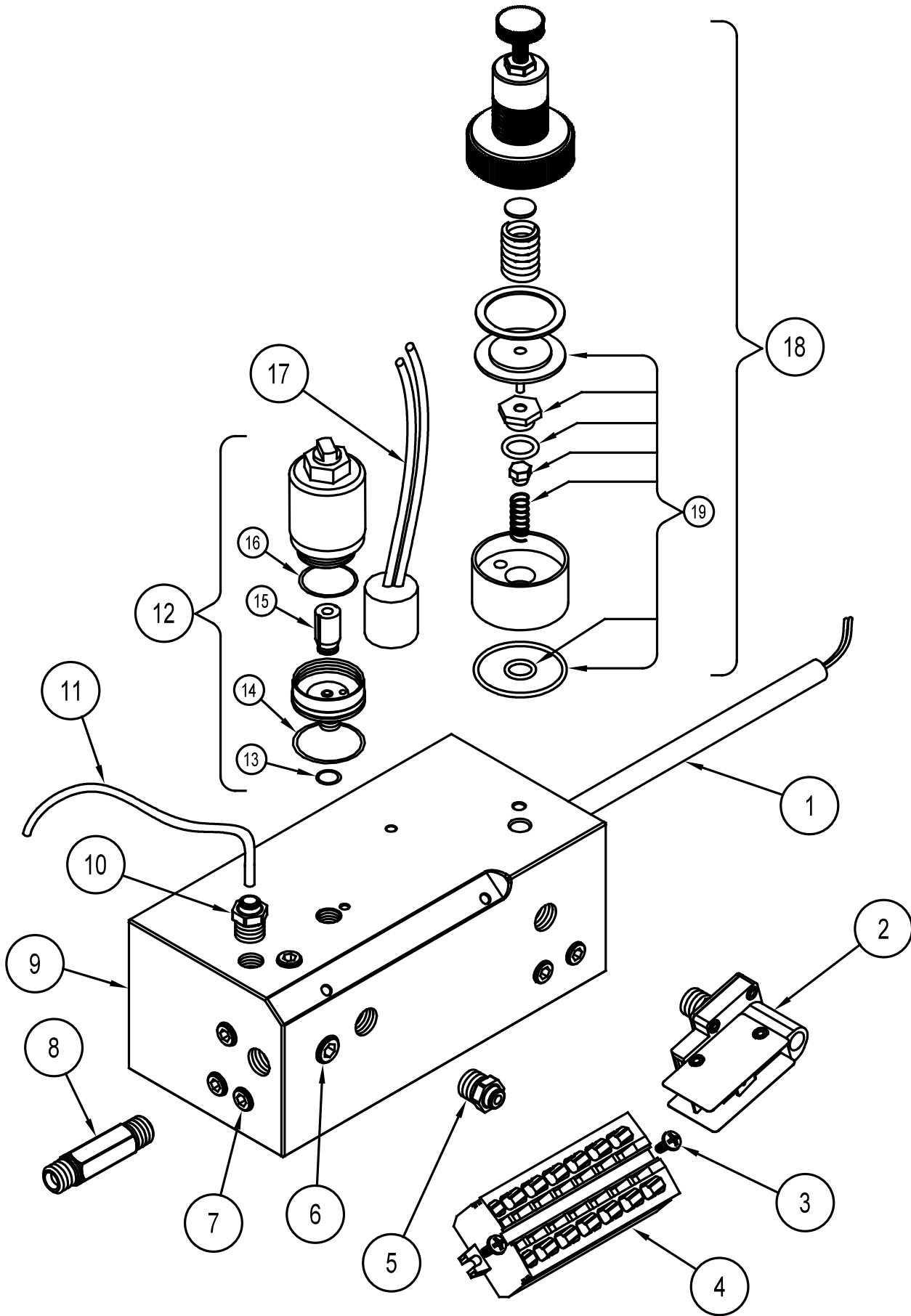

ITEM	PART #	DESCRIPTION	QTY.
1	30002	Heat Element	1
2	50054	Air Pressure Switch	1
3	58029	Machine Screw 8-32 x 3/8 Z	2
4	30010	Terminal Block - Burner	1
5	50062	Tube Fitting 1/8T x 1/8 MNPT	1
6	50188	Plug - Hex Socket 1/8 NPT w/ Dry Seal	1
7	50067	Plug - Hex Socket 1/16 NPT w/ Dry Seal	11
8	50064	1/8 x 1-1/2 Nipple	1
9	50008	Burner Manifold Block	1
10	50364	Tube Fitting 5/32 Tube X 1/8 MNPT	1
11	50365	Tubing - Air Line (5/32" OD) High Temp	10"
12	50022	Solenoid Air/Oil 115VAC	1
13	50254	O-Ring Solenoid Small	1
14	50255	O-Ring Solenoid Large	1
15	50256	Plunger - Air/Oil Solenoid	1
16	50253	O-Ring Solenoid Inner	1
17	30011	Thermostat 150F - Heater	1
18	50237	Regulator - Manifold Mount (Screw-In)	1
19	50293	Regulator Parts Kit (Screw-In)	1

* Items 1 and 17 are used in the CE-4 EZ burner only on Model CE-330 / CE-340 / CE-440

CE-140 FURNACE CABINET

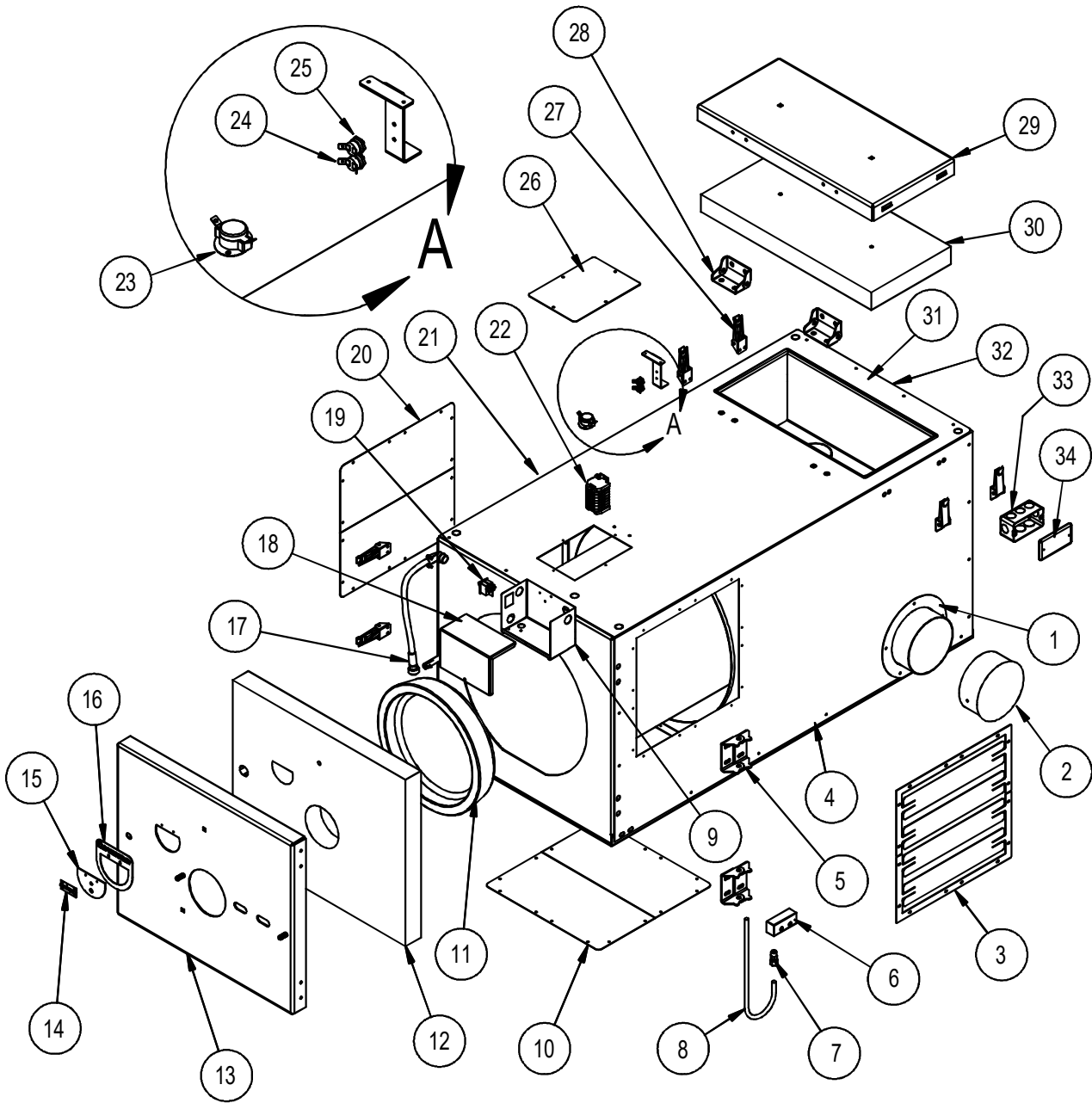

ITEM	PART #	DESCRIPTION	QTY.
	10140	CE 140 Furnace (w/ Burner, Pump, and Blower)	
1	20077	6" Shroud. Ring	2
2	90015	Duct Cap 6"	1
3	20045	Louvers	2
4	20144	Shrouding RH Side CE 140	1
5	20075	Front Door Hinge	4
6	50007	Oil Connector Block	1
7	50042	Swivel 3/8 Comp 1/4 NPT	1
8	50296	Hookup Tube (140/180/250)	1
9	20216	Electrical Box	1
10	20083	Blank Louver Cover half (Galv)	2
11	50001	Soft Target	1
12	50011	Insulation - Front Door	1
13	65007	Front Door	1
14	50010	Hinge - Observation Port	1
15	20080	Observation Port Lid	1
16	20100	Observation Port Ring	1
17	30024	Connector Cord 5 Wire	1
18	20217	Electrical Box Lid	1
19	30072	Burner Power Switch	1
20	20082	Blank Louver Cover Half	2
21	20145	Shroud LH Side CE 140	1
22	30023	Terminal Block	1
23	30008	Thermostat 200F - Fan Switch	1
24	30007	Thermostat 290F - Aux. HL	1
25	30006	Thermostat 200F - HL	1
26	20086	Top Switch Cover	1
27	50082	Overcenter Latch	6
28	20087	Hinge Flue Box Door	4
29	20076	Top Cleanout Door	1
30	50014	Insulation - Top Clean Out Door	1
31	20146	Shroud Top CE 140	1
32	20084	Rear Shrouding	1
33	30040	Electrical Box 2x4	1
34	30041	Electrical Box Cover 2x4	1

CE-180 FURNACE CABINET

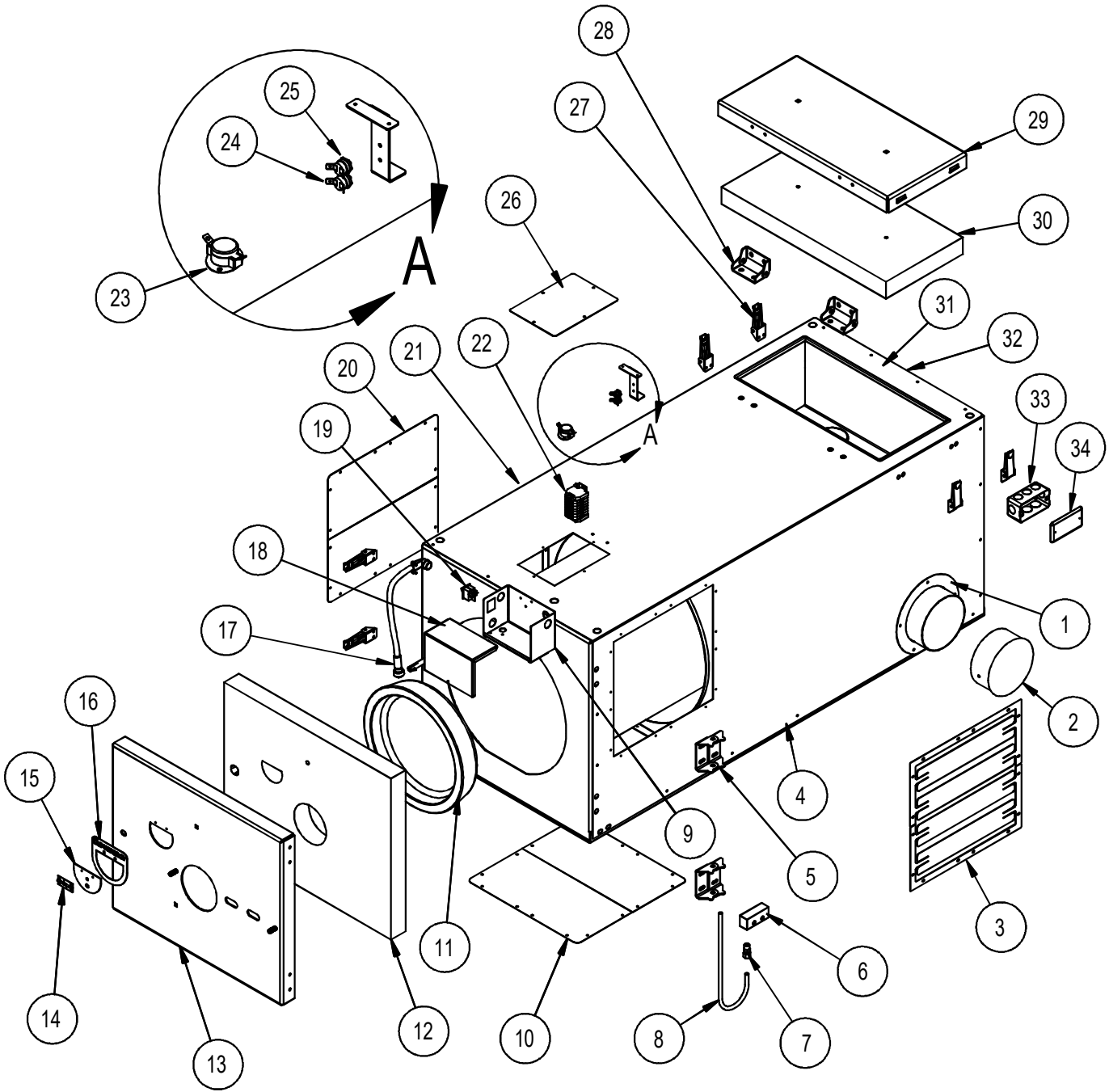

ITEM	PART #	DESCRIPTION	QTY.
	10180	CE 180 Furnace (w/ Burner, Pump, and Blower)	
1	20077	6" Shroud. Ring	2
2	90015	Duct Cap 6"	1
3	20045	Louvers	2
4	20072	Shrouding RH Side CE 180	1
5	20075	Front Door Hinge	4
6	50007	Oil Connector Block	1
7	50042	Swivel 3/8 Comp 1/4 NPT	1
8	50296	Hookup Tube (140/180/250)	1
9	20216	Electrical Box	1
10	20083	Blank Louver Cover half (Galv)	2
11	50001	Soft Target	1
12	50011	Insulation - Front Door	1
13	65007	Front Door	1
14	50010	Hinge - Observation Port	1
15	20080	Observation Port Lid	1
16	20100	Observation Port Ring	1
17	30024	Connector Cord 5 Wire	1
18	20217	Electrical Box Lid	1
19	30072	Burner Power Switch	1
20	20082	Blank Louver Cover Half	2
21	20073	Shroud LH Side CE 180	1
22	30023	Terminal Block	1
23	30008	Thermostat 200F - Fan Switch	1
24	30007	Thermostat 290F - Aux. HL	1
25	30006	Thermostat 200F - HL	1
26	20086	Top Switch Cover	1
27	50082	Overcenter Latch	6
28	20087	Hinge Flue Box Door	4
29	20076	Top Cleanout Door	1
30	50014	Insulation - Top Clean Out Door	1
31	20192	Shroud Top CE 180	1
32	20084	Rear Shrouding	1
33	30040	Electrical Box 2x4	1
34	30041	Electrical Box Cover 2x4	1

CE-140 / 180 BLOWER

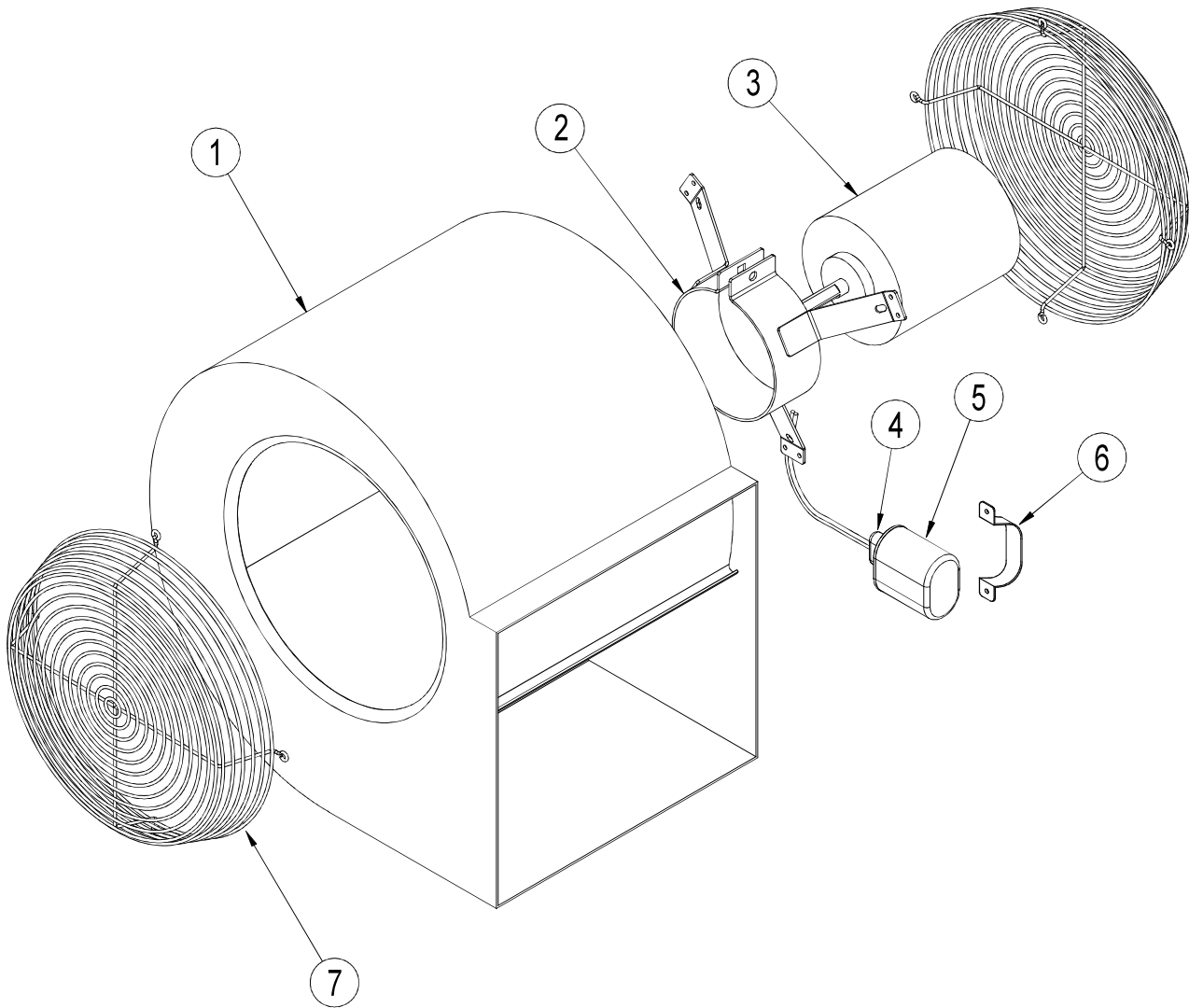

ITEM	PART #	DESCRIPTION	QTY.
	60005	CE 140 / CE 180 Blower Assembly	
1	50013	Blower CE 140 / CE180	1
2	65013	Blower Mtr Bracket (3/4 HP Motor)	1
3	30005	Motor 3/4 HP	1
4	30018	Boot Capacitor	1
5	30012	Capacitor 15 MFD 370V	1
6	50072	Capacitor Strap (15 MFD)	1
7	50018	Blower Guard (CE 140 / CE 180 / CE 250)	2

CE-250 FURNACE CABINET

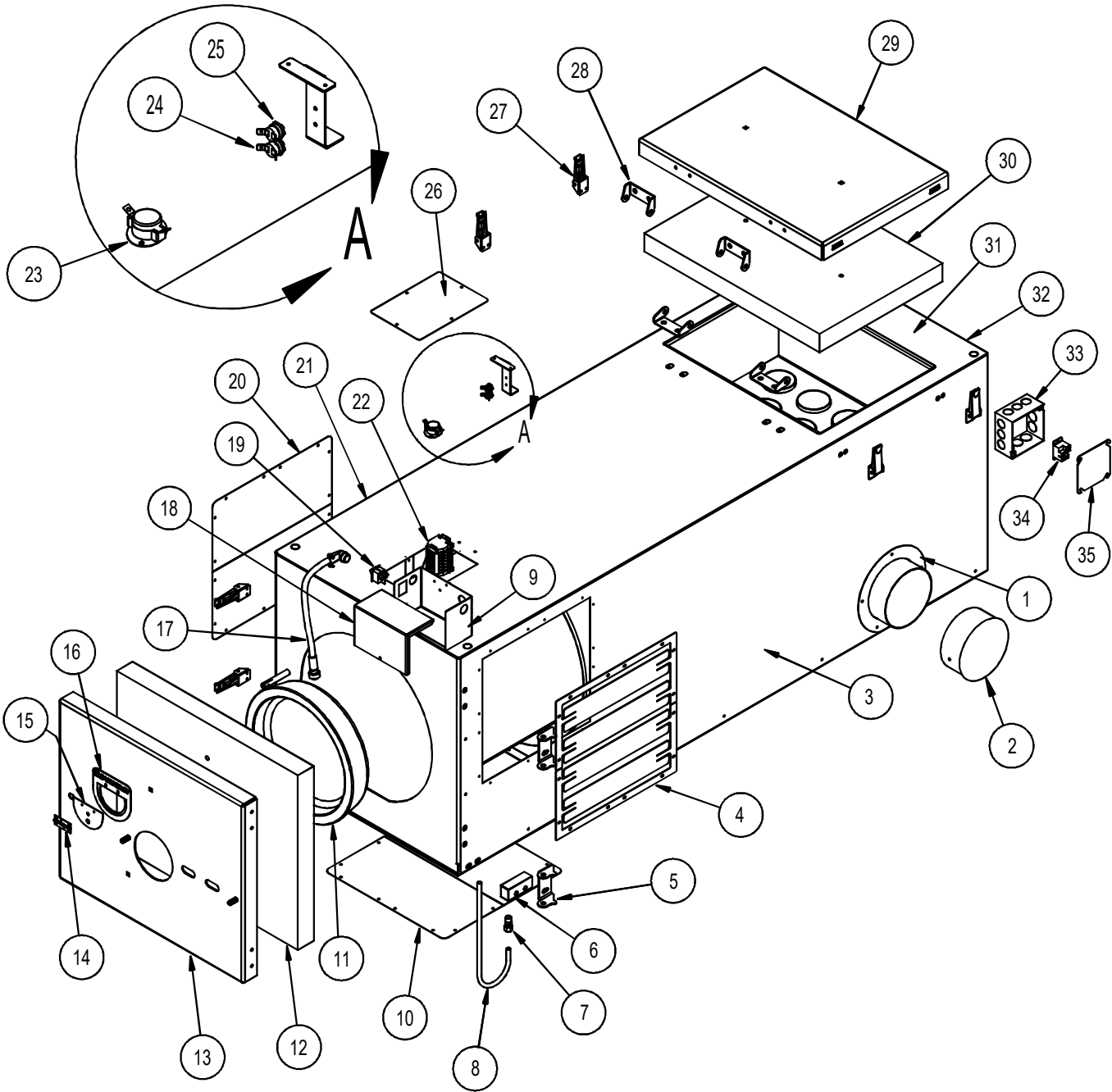

ITEM	PART #	DESCRIPTION	QTY.
	10250	CE 250 Furnace (w/ Burner, Pump, and Blower)	
1	20077	6" Shroud. Ring	2
2	90015	Duct Cap 6"	1
3	20090	Shrouding RH Side CE 250	2
4	20045	Louvers	1
5	20075	Front Door Hinge	4
6	50007	Oil Connector Block	1
7	50042	Swivel 3/8 Comp 1/4 NPT	1
8	50296	Hookup Tube (140/180/250)	1
9	20216	Electrical Box	1
10	20083	Blank Louver Cover half (Galv)	2
11	50001	Soft Target	1
12	50011	Insulation - Front Door	1
13	65007	Front Door	1
14	50010	Hinge - Observation Port	1
15	20080	Observation Port Lid	1
16	20100	Observation Port Ring	1
17	30024	Connector Cord 5 Wire	1
18	20217	Electrical Box Lid	1
19	30072	Burner Power Switch	1
20	20082	Blank Louver Cover Half	2
21	20091	Shroud LH Side CE 250	1
22	30023	Terminal Block	1
23	30008	Thermostat 200F - Fan Switch	1
24	30007	Thermostat 290F - Aux. HL	1
25	30006	Thermostat 200F - HL	1
26	20086	Top Switch Cover	1
27	50082	Overcenter Latch	6
28	20087	Hinge Flue Box Door	4
29	20094	Top Cleanout Door	1
30	50012	Insulation - Top Clean Out Door	1
31	20193	Shroud Top CE 250	1
32	20093	Rear Shrouding	1
33	30042	Electrical Box 4x4	1
34	30009	Relay SPST	1
35	30043	Electrical Box Cover 4x4	1

CE-250 BLOWER

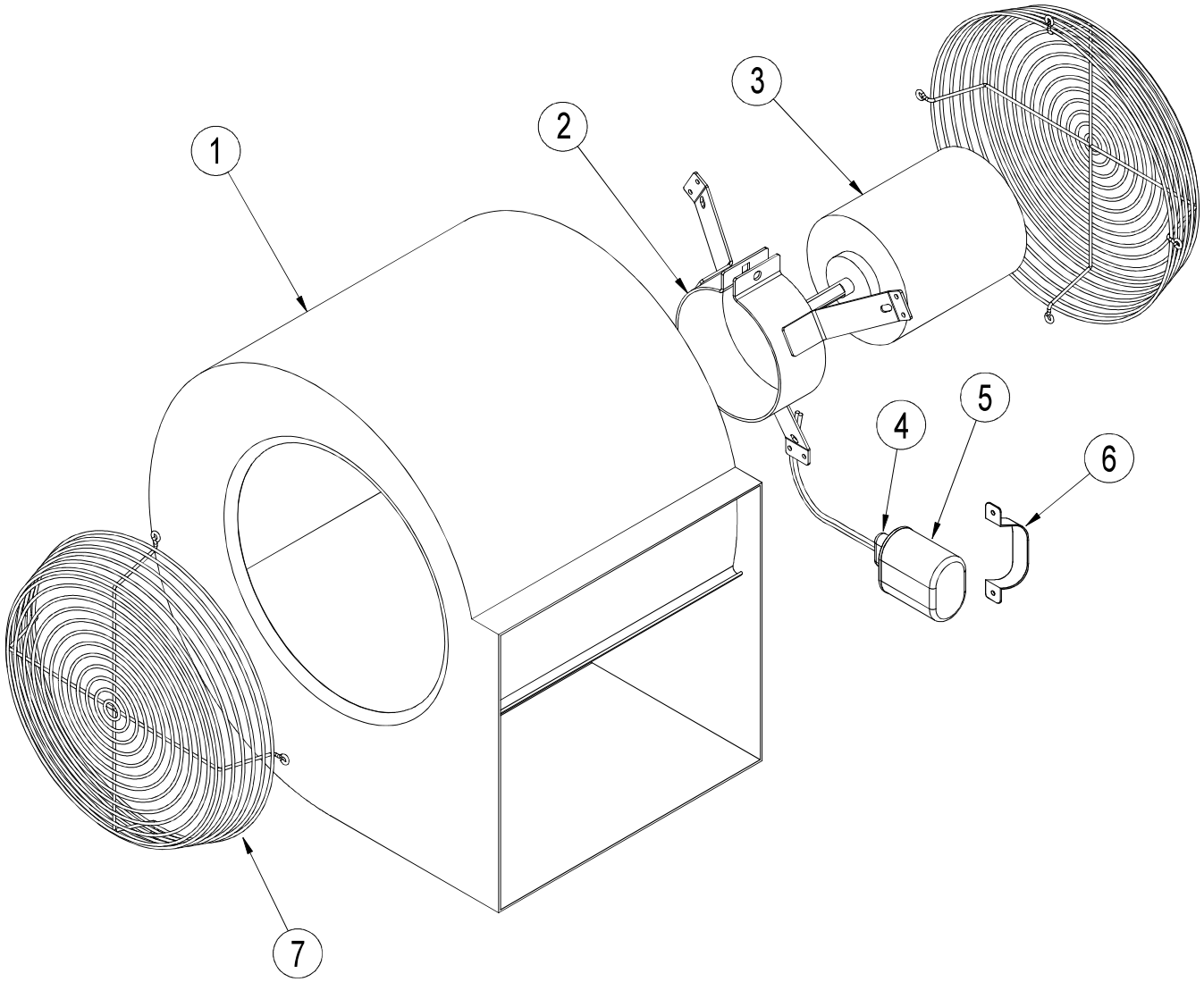

ITEM	PART #	DESCRIPTION	QTY.
	60006	CE 250 Blower Assembly	
1	50002	Blower CE250	1
2	65014	Blower Mtr Bucket (1 HP)	1
3	30004	Motor 1HP	1
4	30018	Boot Capacitor	1
5	30013	Capacitor 30 MFD 370V	1
6	50073	Capacitor Strap (30 MFD)	1
7	50018	Blower Guard (CE 140 / CE 180 / CE 250)	2

ITEM	PART #	DESCRIPTION	QTY.
	10330	CE 330 Furnace (w/ Burner, Pump, and Blower)	
1	20126	8" Shroud. Ring	2
2	90159	Duct Cap 8"	1
3	20122	Shrouding RH Side CE 330	2
4	20128	Louvers	1
5	20075	Front Door Hinge	4
6	50007	Oil Connector Block	1
7	50042	Swivel 3/8 Comp 1/4 NPT	1
8	50297	Hookup Tube (CE 330)	1
9	20216	Electrical Box	1
10	20131	Blank Louver Cover half (CE 330) Galv	2
11	50001	Soft Target	1
12	50011	Insulation - Front Door	1
13	65007	Front Door	1
14	50010	Hinge - Observation Port	1
15	20080	Observation Port Lid	1
16	20100	Observation Port Ring	1
17	30024	Connector Cord 5 Wire	1
18	20217	Electrical Box Lid	1
19	30072	Burner Power Switch	1
20	20130	Blank Louver Cover half (CE 330)	2
21	20123	Shroud LH Side CE 330	1
22	30023	Terminal Block	1
23	30008	Thermostat 200F - Fan Switch	1
24	30007	Thermostat 290F - Aux. HL	1
25	30006	Thermostat 200F - HL	1
26	20086	Top Switch Cover	1
27	50082	Overcenter Latch	6
28	20087	Hinge Flue Box Door	4
29	20127	Top Cleanout Door (330)	1
30	50133	Insulation - Top Clean Out Door (330)	1
31	20194	Shroud Top CE 330	1
32	20125	Rear Shrouding (CE 330)	1
33	20009	Electrical Box Back	1
34	30059	2 Pole Contactor	1
35	20010	Electrical Box Lid (Back)	1

CE-330 BLOWER

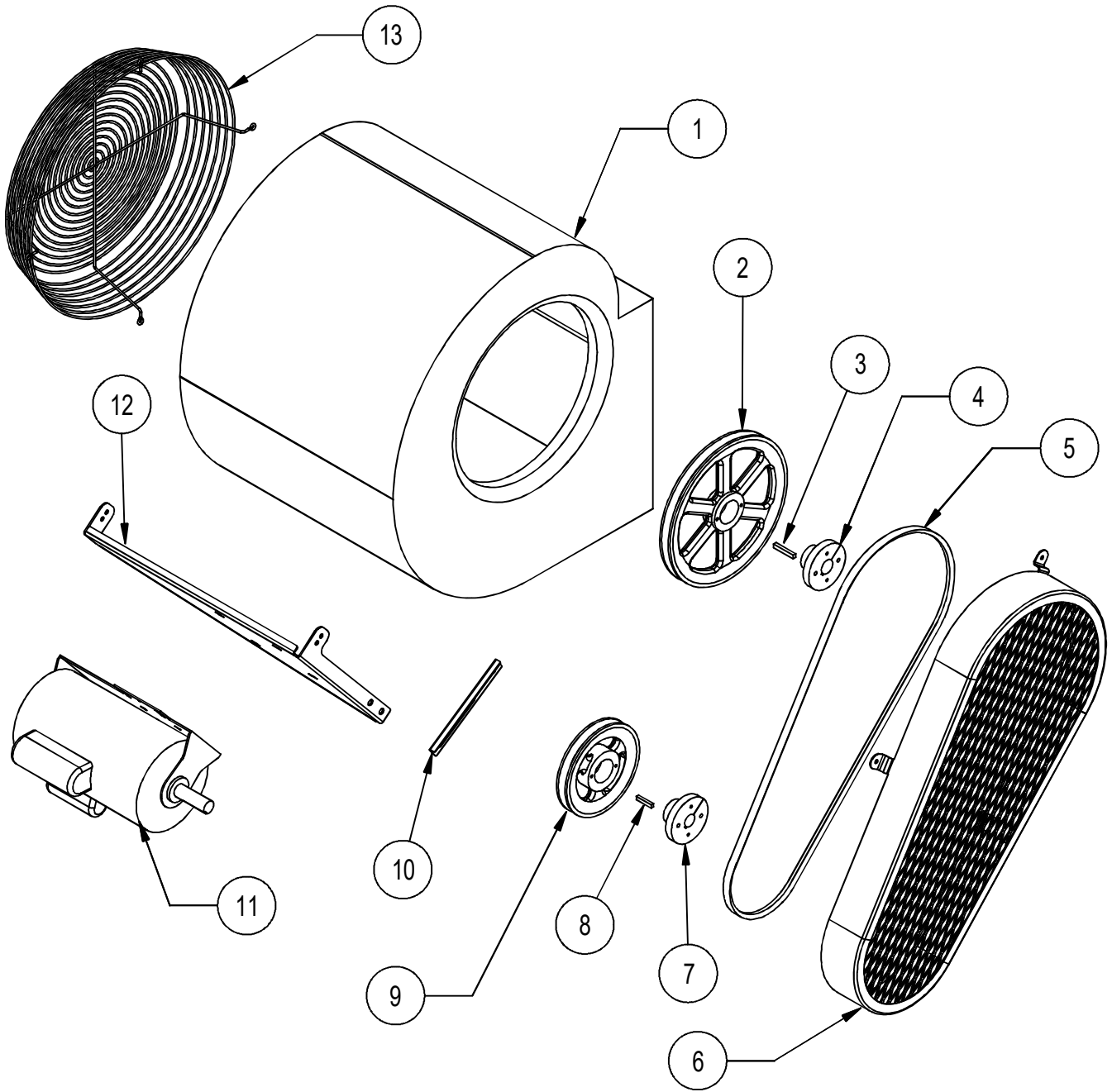

ITEM	PART #	DESCRIPTION	QTY.
1	50126	CE330 Blower Housing	1
2	50127	CE330 Blower Pulley	1
3	50242	Key (CE 330 Blower Shaft)	1
4	50129	CE330 Blower Wheel Bushing - 1"	1
5	50131	CE330 Blower Drive Belt	1
6	65023	Belt Guard (CE 330) WA	1
7	50170	CE330 Blower Motor Bushing - 5/8"	1
8	50246	Key (CE 330 Blower Motor Shaft)	1
9	50128	CE330 Blower Motor Pulley	1
10	20133	Tensioning Bracket	1
11	30060	CE330 Blower Motor (2 HP)	1
12	20132	Blower Motor Mount CE330	1
13	50123	Blower Guard	1

CE-440 FURNACE CABINET

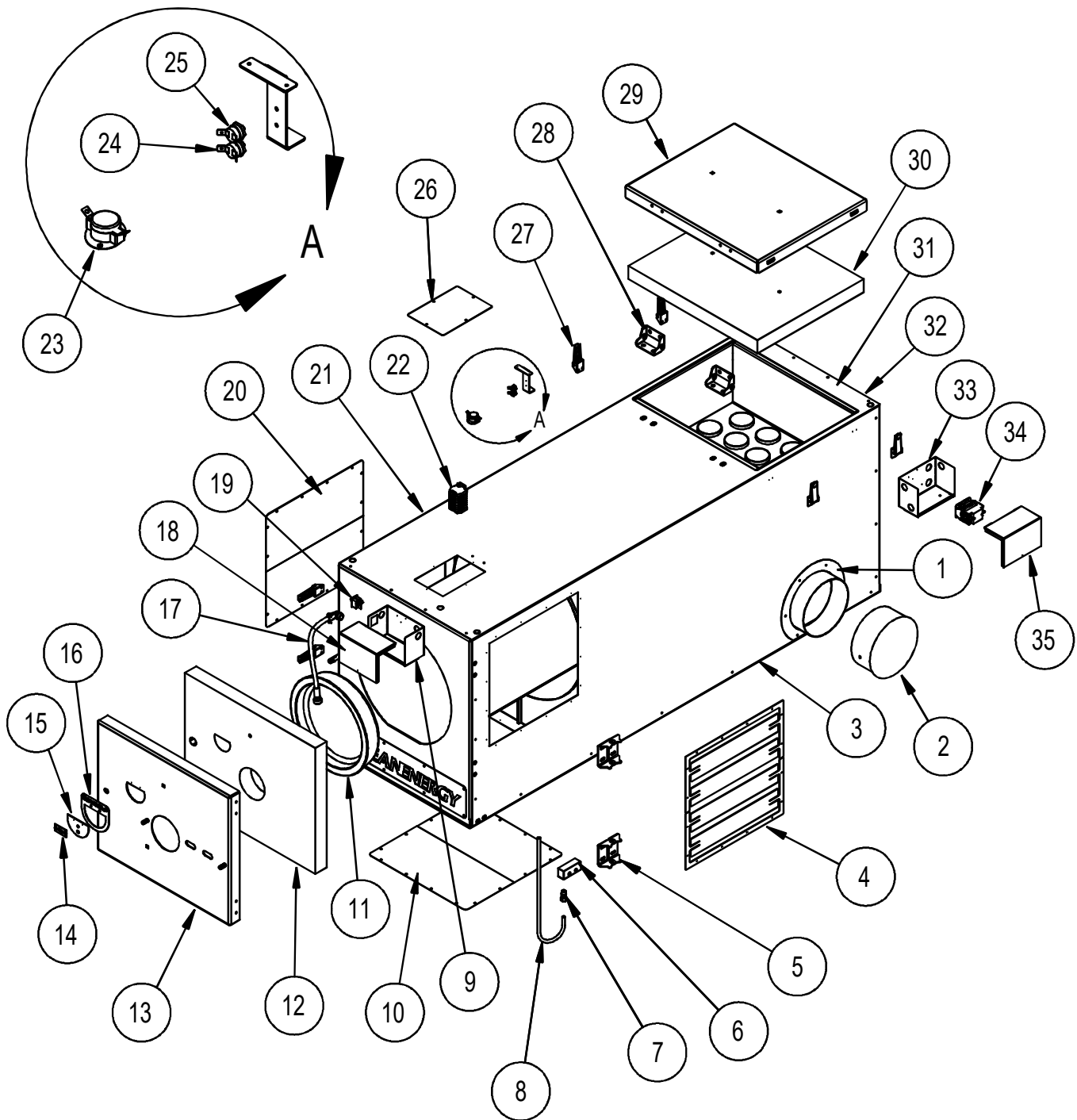

ITEM	PART #	DESCRIPTION	QTY.
	10440	CE 440 Furnace (w/ Burner, Pump, and Blower)	
1	20126	8" Shroud. Ring	2
2	90159	Duct Cap 8"	1
3	20290	Shrouding RH Side CE 440	1
4	20273	Louvers CE 440	2
5	20075	Front Door Hinge	4
6	50007	Oil Connector Block	1
7	50042	Swivel 3/8 Comp 1/4 NPT	1
8	50297	Hookup Tube (CE 330/CE 440)	1
9	20216	Electrical Box	1
10	20288	Blank Louver Cover half (CE 440) Galv	2
11	50001	Soft Target	1
12	50362	Insulation - Front Door CE 440	1
13	65042	Front Door CE 440	1
14	50010	Hinge - Observation Port	1
15	20080	Observation Port Lid	1
16	20100	Observation Port Ring	1
17	30024	Connector Cord 5 Wire	1
18	20217	Electrical Box Lid	1
19	30072	Burner Power Switch	1
20	20287	Blank Louver Cover half (CE 440)	2
21	20291	Shroud LH Side CE 440	1
22	30023	Terminal Block	1
23	30008	Thermostat 200F - Fan Switch	1
24	30007	Thermostat 290F - Aux. HL	1
25	30006	Thermostat 200F - HL	1
26	20086	Top Switch Cover	1
27	50082	Overcenter Latch	6
28	20087	Hinge Flue Box Door	4
29	20294	Top Cleanout Door (440)	1
30	50361	Insulation - Top Clean Out Door (440)	1
31	20292	Shroud Top CE 440	1
32	20293	Rear Shrouding (CE 440)	1
33	20009	Electrical Box Back	1
34	30059	2 Pole Contactor	1
35	20010	Electrical Box Lid (Back)	1

CE-440 BLOWER

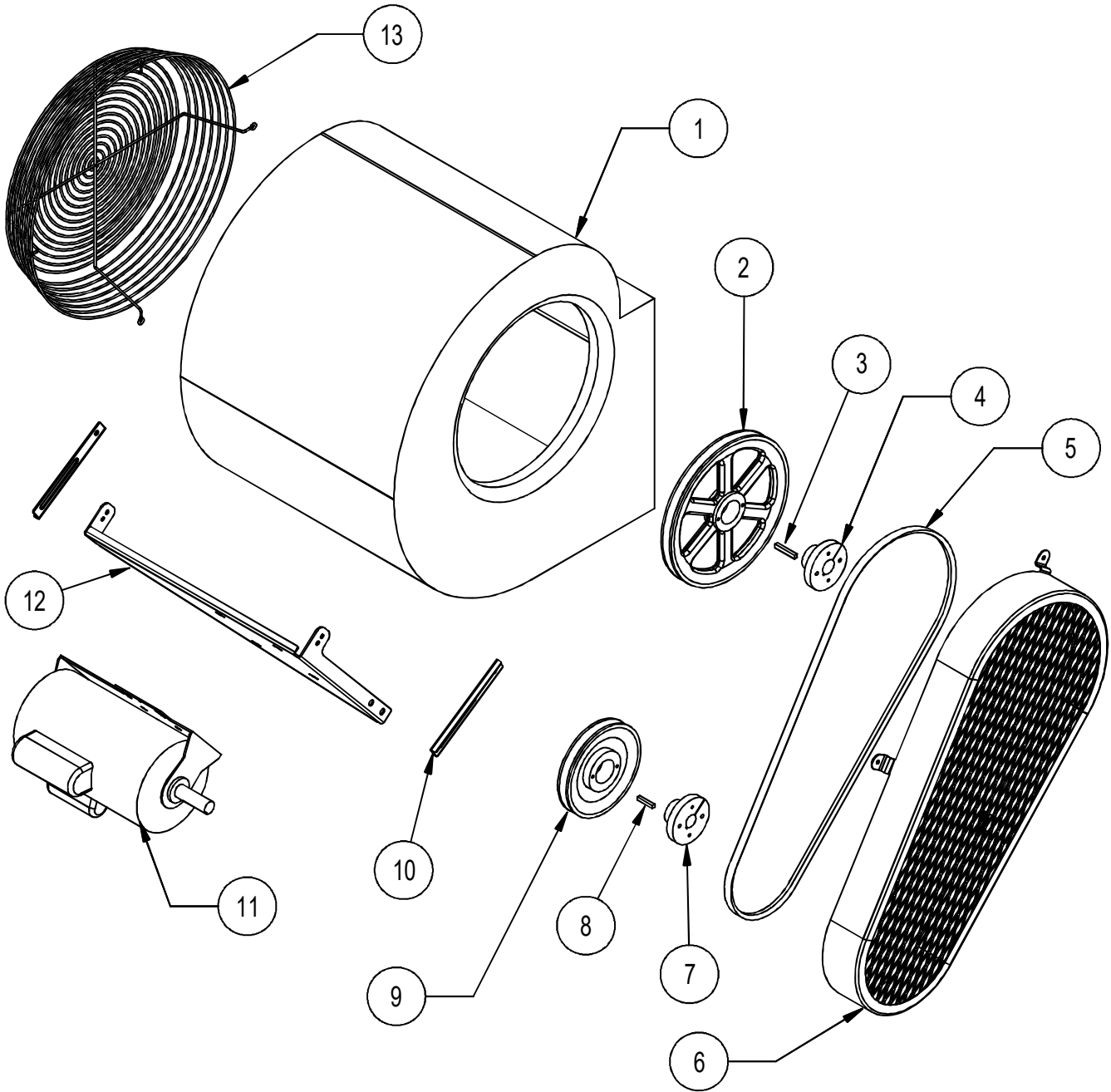

ITEM	PART #	DESCRIPTION	QTY.
1	50357	CE440 Blower Housing	1
2	50127	CE330 / CE 440 Blower Pulley	1
3	50242	Key (CE 330 / CE 440 Blower Shaft)	1
4	50129	CE330 / CE 440 Blower Wheel Bushing - 1"	1
5	50377	CE440 Blower Drive Belt	1
6	65040	Belt Guard (CE 440) WA	1
7	50170	CE330 / CE 440 Blower Motor Bushing - 5/8"	1
8	50246	Key (CE 330 / CE 440 Blower Motor Shaft)	1
9	50376	CE440 Blower Motor Pulley	1
10	20133	Tensioning Bracket	2
11	30060	Blower Motor (2 HP)	1
12	20296	Blower Motor Mount CE440	1
13	50123	Blower Guard	1

METERING PUMP ASSEMBLY

WITH A2RA-7720 PUMP HEAD:

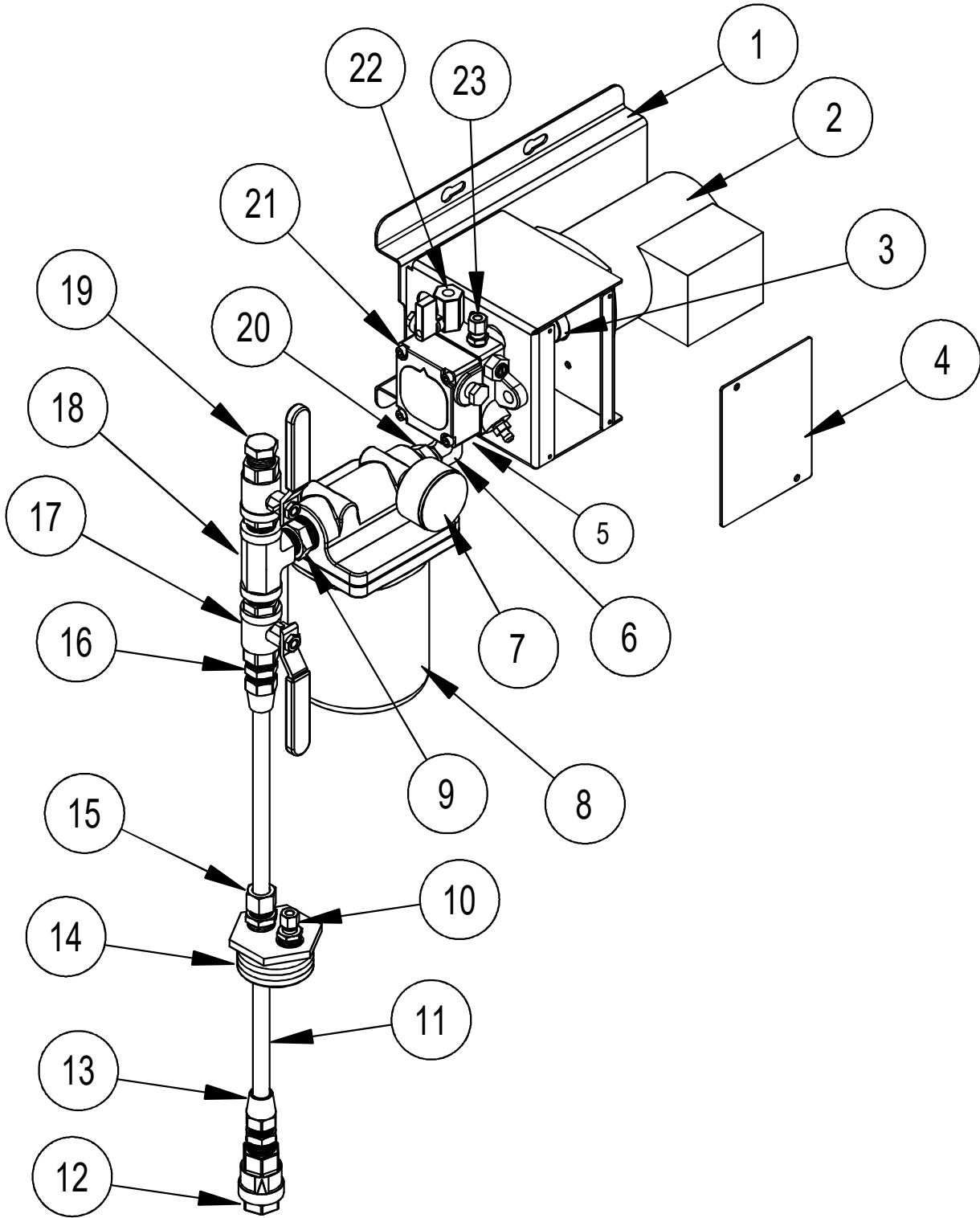

Item	Part #	Description	Qty.
	60081	CE 140 Pump Assembly	
	60082	CE 180 Pump Assembly	
	60083	CE 250 Pump Assembly	
	60084	CE 330 Pump Assembly	
	60085	CE 340 Pump Assembly	
	60089	CE 440 Pump Assembly	
1	65027	Metering Pump Housing Assembly	1
*2	50331	Gearmotor - CE 140	1
*2	50332	Gearmotor - CE 180	1
*2	50333	Gearmotor - CE 250	1
*2	50334	Gearmotor - CE 330	1
*2	50335	Gearmotor - CE 340	1
*2	50358	Gearmotor - CE 440	1
3	40019	Metering Pump Coupling	1
4	20225	Metering Pump Cover	1
5	50028	Nipple 1/4 NPT Hex Plated	1
6	50026	ST EL 90° 1/4 F x 1/4 M	1
7	50006	Gauge for Filter	1
8	50005	Filter	1
9	50031	Bushing 3/4 x 1/2 NPT	1
10	50036	1/2" MNPT x 1/4 Comp.	1
11	USER SUPPLIED	1/2" Copper Tubing	
12	50070	Foot Valve 1/2"	1
13	50034	1/2 Flare Nut 45°	2
14	50044	Duplex Fitting 2"	1
15	50035	Slip Through Fitting 1/2" MNPT	1
16	50033	1/2 Flare x 1/2 NPT Brass	2
17	50053	Ball Valve 1/2 NPT	2
18	50037	Tee 1/2 F x 1/2 F x 1/2 M	1
19	50038	Plug 1/2 NPT Hex	1
20	50030	Bushing 3/4 x 1/4 NPT	1
21	40014	Metering Pump (A2RA-7720)	1
22	50238	Ball Valve - Mini (1/8")	1
23	50241	Straight Adapter 1/4" T x 1/8" MNPT	1
	40007	Strainer and Gasket Kit (Pump Head)	
	40008	Screen Element (Lenz Filter)	
	40009	O-Ring (Lenz Filter)	

*NOTE: The gearmotor in the pump assembly may differ when the installation is located at high elevation. Contact your Local Representative or Clean Energy Heating Systems for more information.

Through the Wall Chimney Installation:

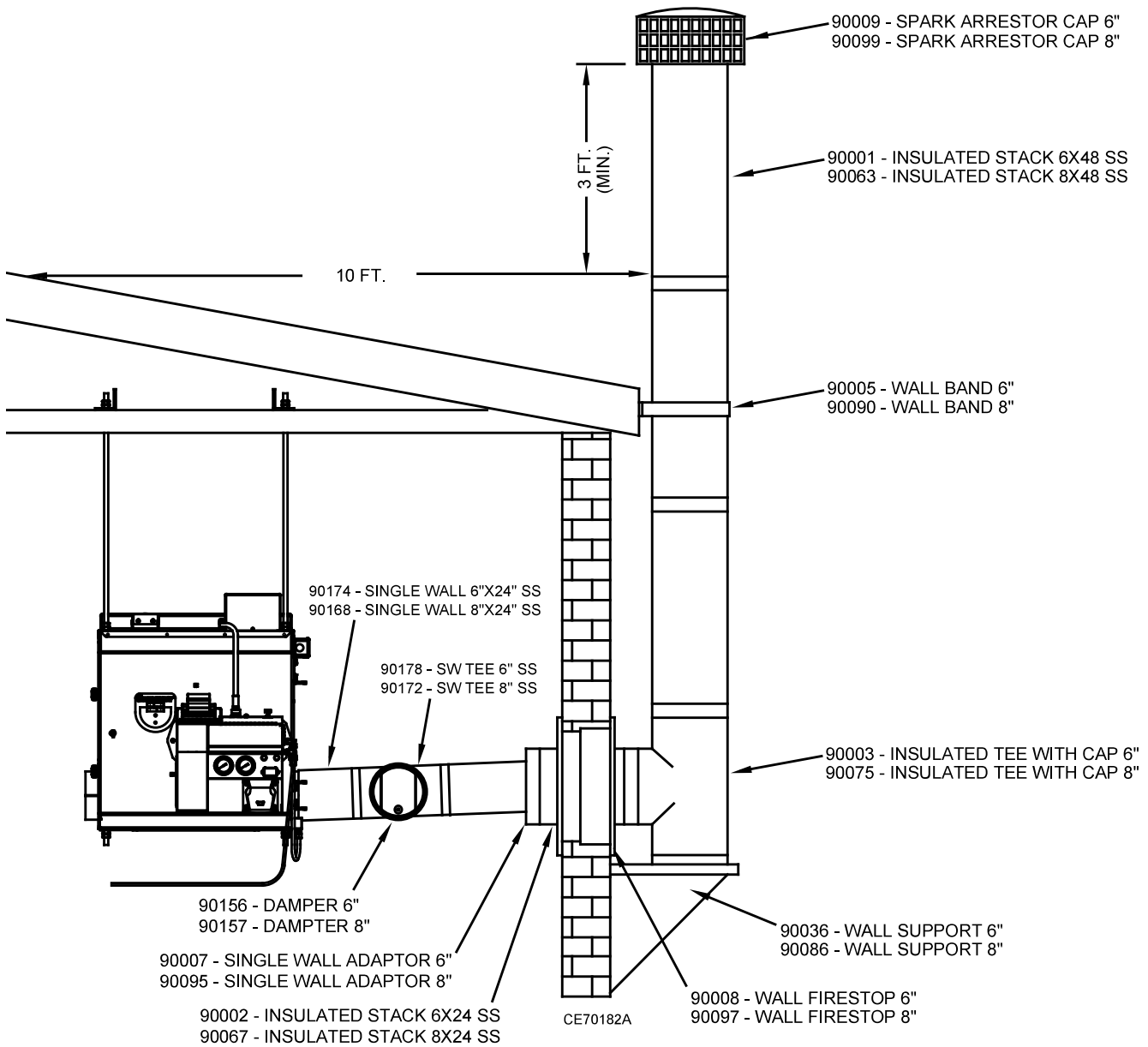

- 90010 - STORM COLLAR 6"
- 90011 - FLASHING 2/12 - 5/12 6"
- 90051 - FLASHING 6/12 - 10/12 6"
- 90155 - DEKTITE BOOT #7 (KIT)

- 90102 - STORM COLLAR 8"
- 90106 - FLASHING 2/12 - 5/12 8"
- 90108 - FLASHING 6/12 - 10/12 8"
- 90158 - DEKTITE BOOT #9 (KIT)

- 90018 - INSULATED STACK 6X36 SS
- 90021 - INSULATED STACK 6X18 SS
- 90023 - INSULATED STACK 6X12 SS

- 90065 - INSULATED STACK 8X36 SS
- 90069 - INSULATED STACK 8X18 SS
- 90071 - INSULATED STACK 8X12 SS

Through the Roof Chimney Installation:

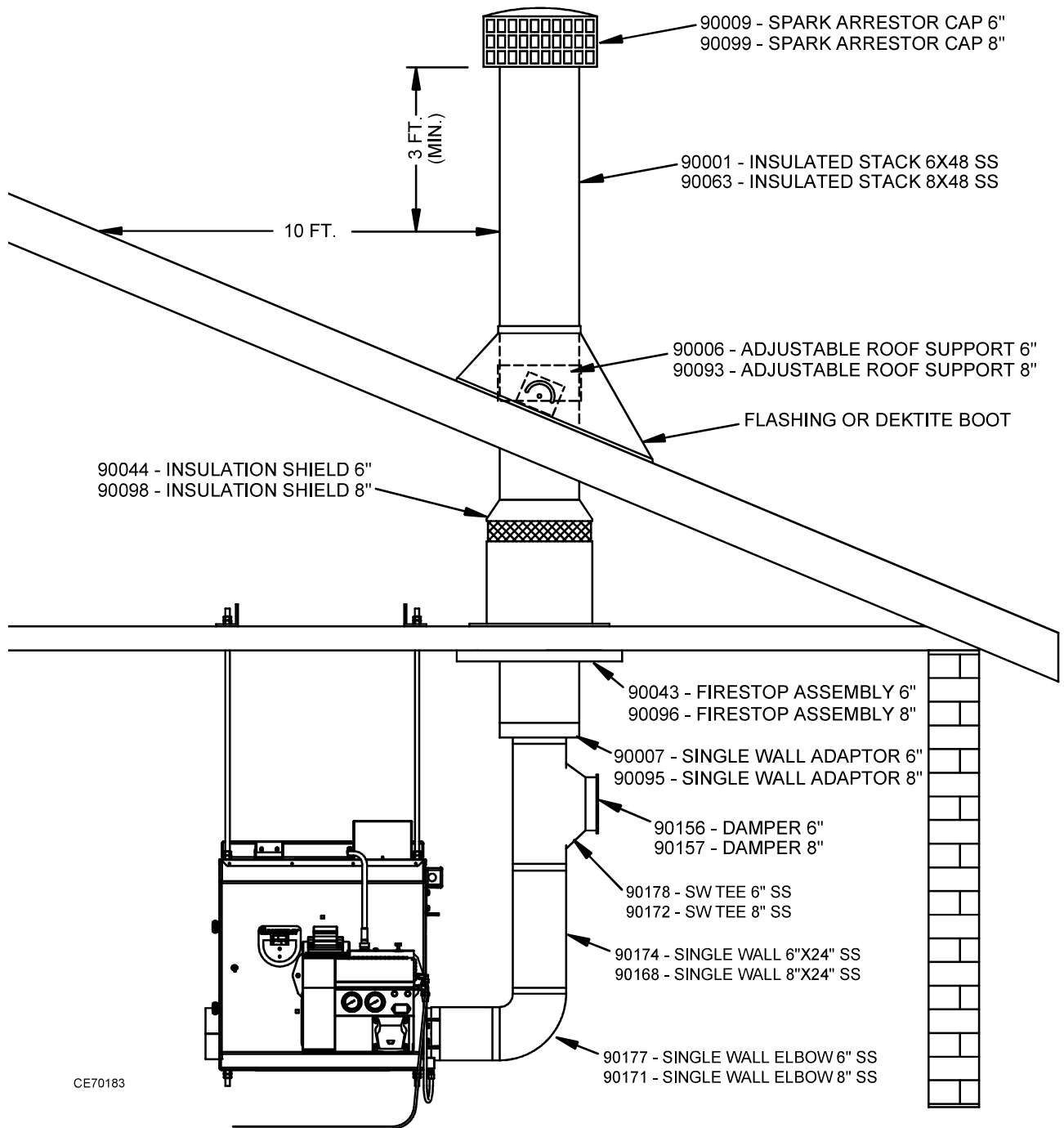

- 90004 - CEILING SUPPORT 6" (USED WITH INSULATED CEILING)
- 90010 - STORM COLLAR 6"
- 90011 - FLASHING 2/12 - 5/12 6"
- 90051 - FLASHING 6/12 - 10/12 6"
- 90155 - DEKTITE BOOT #7 (KIT)

- 90082 - CEILING SUPPORT 8" (USED WITH INSULATED CEILING)
- 90102 - STORM COLLAR 8"
- 90106 - FLASHING 2/12 - 5/12 8"
- 90108 - FLASHING 6/12 - 10/12 8"
- 90158 - DEKTITE BOOT #9 (KIT)

- 90018 - INSULATED STACK 6X36 SS
- 90021 - INSULATED STACK 6X18 SS
- 90023 - INSULATED STACK 6X12 SS

- 90065 - INSULATED STACK 8X36 SS
- 90069 - INSULATED STACK 8X18 SS
- 90071 - INSULATED STACK 8X12 SS

CLEAN ENERGY HEATING SYSTEMS LLC MODELS: CE-140/CE-180/CE-250/CE-330/CE-440

TWELVE YEAR Combustion Chamber/Heat Exchanger Warranty

- From date of purchase when Warranty Card is returned within 30 days
- From date of sale from Manufacturer without returned Warranty Card

36 MONTHS Parts Warranty (From date of purchase when Warranty Card is returned within 30 days)

18 MONTHS Parts Warranty (From date of sale from Manufacturer without returned Warranty Card)

Clean Energy Heating Systems LLC, MANUFACTURER, hereby warrants the MANUFACTURER'S product to be free from defects in material and workmanship under normal use and conditions as set forth in the provisions and limitations below. The warranty extends to the original owner whose name appears on the Warranty Registration Card returned to MANUFACTURER.

TWELVE YEAR COMBUSTION CHAMBER / HEAT EXCHANGER WARRANTY

The TWELVE YEAR Combustion Chamber/Heat Exchanger Warranty shall extend to the original purchaser and shall be subject to the schedule of years OR hours, whichever comes first, listed below:

0 to 12 years (Less than 18,000 hours) Repair or replace FREE of charge

All labor and transportation costs are the responsibility of the owner. Repair or replacement shall be determined by MANUFACTURER. Photos or returned goods at owner's expense may be required for warranty determination.

PARTS WARRANTY

Parts are covered under warranty for 36 MONTHS from date of purchase when the Warranty Card is returned (18 MONTHS from date of sale from Manufacturer without returned Warranty Card). Owner is responsible for all labor and transportation costs associated with warranty claims.

CONDITIONS AND LIMITATIONS:

- A. WEAR ITEMS are not covered under warranty (*nozzles, o-rings, target, belts, filters/gaskets*)
- B. The owner must complete and return the Warranty Registration Card within thirty (30) days of purchase to activate 36 MONTHS Parts Warranty Coverage.
- C. The equipment must be fired at rated capacity only with fuels listed on data label.
- D. The equipment must be installed, operated, and maintained in accordance with Federal, State, and Local regulations as well as with all MANUFACTURER'S installation and operating instructions.
- E. The equipment must not be installed in any corrosive atmosphere environment.
- F. No parts or controls may be modified, altered, or by-passed.
- G. MANUFACTURER shall not be responsible for any failure due to an Act of God.
- H. MANUFACTURER is not responsible for additions or changes made by a dealer or distributor that goes beyond the terms of this Warranty.

Clean Energy Heating Systems, LLC assumes no liability for consequent damage of any kind, and by acceptance of this equipment the purchaser assumes all liability for the consequence of its use or misuse by the purchaser or others.



CLEAN ENERGY HEATING SYSTEMS, LLC
WARRANTY CARD
(PLEASE PRINT CLEARLY)

FIRST NAME _____ LAST NAME _____

COMPANY NAME _____

STREET _____ CITY _____ STATE _____ ZIP CODE _____

TELEPHONE _____ EMAIL _____ DATE OF PURCHASE: _____

FURNACE MODEL:

CE-140 CE-250 CE-440

CE-180 CE-330

BURNER MODEL:

CE-3

CE-4

BURNER SERIAL NO. _____

FURNACE SERIAL NO. _____

WITHIN 30 DAYS OF PURCHASE RETURN WARRANTY CARD TO: CLEAN ENERGY HEATING SYSTEMS LLC
PO Box 1341
HONEY BROOK PA USA 19344

Approved Method to
Dispose of Waste Oil



United States
Environmental Protection
Agency



Clean Energy Heating Systems, LLC
PO Box 1341, 479 Maple Street, Honey Brook, PA 19344
www.CleanEnergyHeatingSystems.com
(888) 519-2347

PLACE STAMP HERE

CLEAN ENERGY HEATING SYSTEMS LLC
PO Box 1341
HONEY BROOK PA USA 19344