



633 N Helena St, Spokane, WA 99202
 509.535.1555 | info@northstardirect.com
 1210 N Oregon Ave, Pasco, WA 99301
 509.547.2323 | info@northstarhotsy.com



UNIVERSAL CLARIFIER

CUSTOMIZED UNMATCHED CAPABILITY



VERSATILE WATER TREATMENT TAILORED TO FIT YOUR WATER QUALITY REQUIREMENTS.

The Water Maze Universal Clarifier is designed to be the platform around which your wash water treatment solution is built. The unit can be configured in one of four ways to best address your critical contaminants. External component options are tailored to each configuration to give you unmatched capability to tailor the perfect solution to your water treatment challenge.

This guide will walk you through the different configurations and options to make sure you know what's included with your system and can buy with confidence.



Installation of Universal Clarifier with Integrated Compact CoAg and paired with ZCF and REC modules systems



OIL / WATER SEPARATION

WASH WATER TREATMENT

Apply one treatment module to various water treatment applications:

- Treat & discharge
- Pretreatment for recycle applications
- Pretreatment to water evaporation

Select from a menu of water treatment technologies tailored to match your application requirements

Technologies integrated into one module to achieve the best water quality, at the most economical price

Base Unit Footprint:
 CLT-300: 45 x 45 x 86
 CLT-600: 55 x 55 x 104

Universal Clarifier dimensions vary depending on configurations

APPLICATION / PRODUCTS SELECTION GUIDE

- STEP 1 What constituents in the water need to be removed?
- STEP 2 What water quality requirements need to be achieved?
- STEP 3 What are the characteristics of the constituents that need to be removed?
- STEP 4 Select the clarifier size and appropriated water treatment technologies to fit.

CHARACTERISTICS OF THE CONSTITUENTS

The pH of the water is too high or too low (6.5 - 8.5)

Free-floating or emulsified oils exist in the water

Suspended solids that won't settle

Heavy metals need to be removed from the water

Dissolved organic matter is causing malodorous conditions

SELECTION OF TECHNOLOGIES

pH control system

Oil-skimmer

Chemical coagulation / flocculation

Internal piping manifold

MetalR+ chemical injection

Ozone system

Bio-Digester with PM-1000D

1 NATURAL CLARIFIER TANK

The standard no-frills clarifier configuration. This is the basic shell that all forms of the Universal Clarifier are built around. Cylindrical cone bottom tank available in 300 and 600 gallon capacities. Fully removable top for easy access inside the body of the clarifier. Perfect for use as a holding tank where periodic purging of settleable solids is necessary.

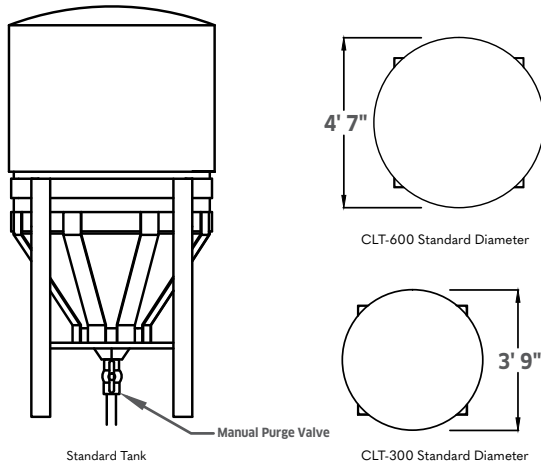

2 COALESCING CONES

The Coalescing Cone configurations add a set of internal cones to the Natural Clarifier format. These cones direct the flow of dirty water through the cone stack and force free oil to agglomerate into larger drops as the water moves up through the clarifier. These larger drops of oil will separate more readily from the water and float to the top, where it can be skimmed off and separated. The treated water is pulled off below the oil rich surface. Additional cones can be installed for applications where oil concentrations tend to be higher.

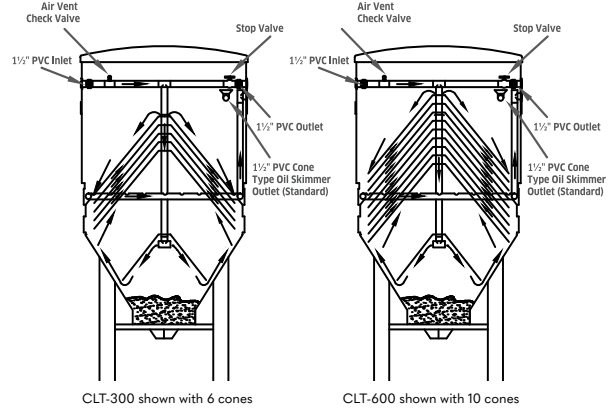

3 TANK-IN-TANK

The Tank-in-Tank configuration adds a small mixing chamber inside the body of the clarifier. This configuration is used exclusively for solids removal when chemicals have been added upstream of the clarifier and need to be gently mixed to fully react. By the time the water flows out the bottom of the smaller tank, the chemicals have flocculated to solids into larger clumps which will settle quickly to the bottom of the clarifier and allow the treated water to flow out the top.

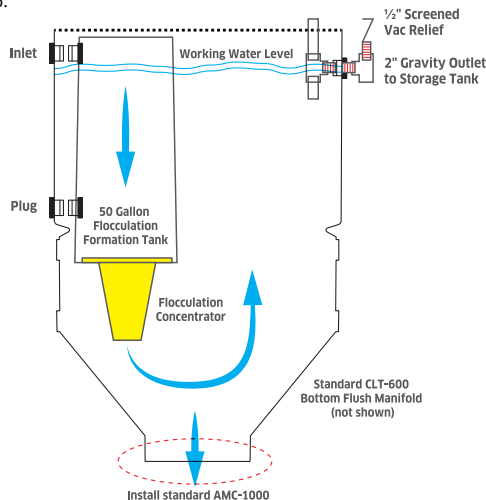

4 BIO-DIGESTER

Bio-digestion is the best way to treat dissolved organic chemicals in your water. To convert the Universal Clarifier into an aggressive bioreactor, we load it with high surface area fill material that allows the microbes to establish high concentration and activity levels in the clarifier. We also connect a PM-1000D aeration and recirculating system to manage feeding the microbes the necessary amount of air and nutrients to allow them to thrive and chew up your contaminants as quickly as possible.

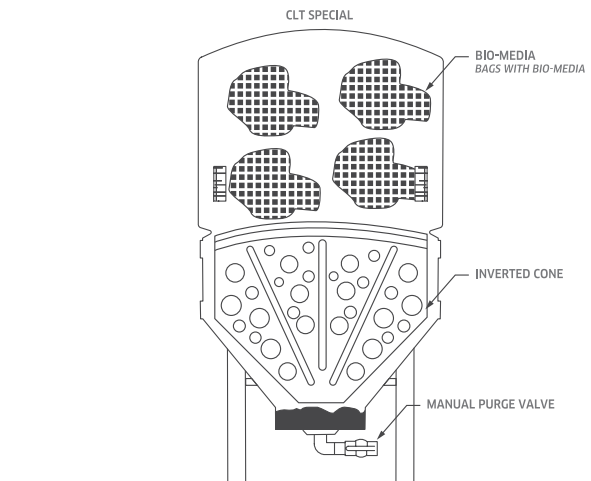

OIL/WATER SEPARATION FREE-FLOATING AND EMULSIFIED



Oil/water separators generally separate free-floating oils from the surface of water, but have little effect on removing emulsified oils or soluble oils.

Traditional oil skimmers are applied to applications where the oils are buoyant and are floating on the surface of the water.

When oils are chemically emulsified and dispersed within the water to “de-emulsify” the oils chemical coagulation / flocculation are applied.

COAGULATION / FLOCCULATION SUSPENDED SOLIDS, EMULSIFIED OILS, AND HEAVY METALS



Coagulation/flocculation water treatment technology is used to remove suspended particles and/or emulsified oils. Particles are suspended due to natural ionic charges that are present in the water. For emulsified oils, the use of cleaning agents create similar ionic charges around oil droplets. In either case, these common charges create repelling forces to suspend matter.

EXTERNAL CONFIGURATION OPTIONS

Once you have determined the necessary internal configuration of your Universal Clarifier, you will need to work with your Water Maze Applications Engineer to determine what external controls and chemicals will be necessary for your application.

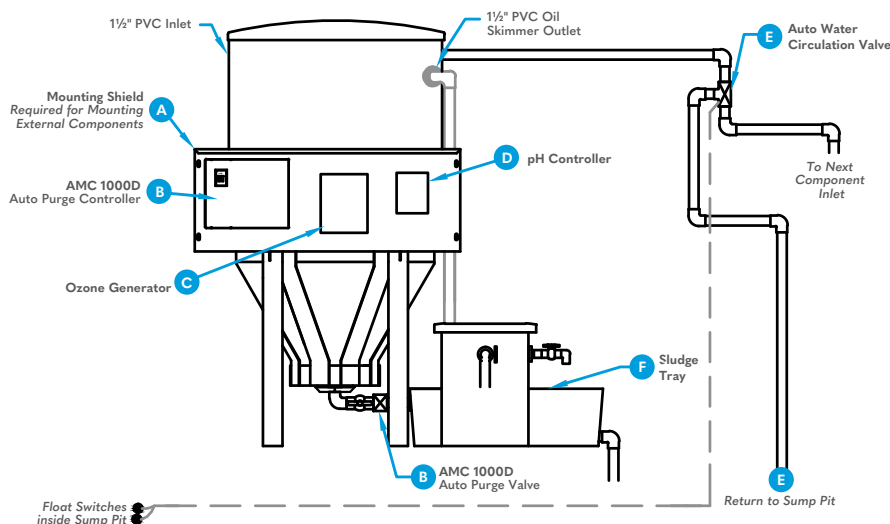

A MOUNTING SHIELD

A simple way to mount external options, this bracket and shield is required when selecting any combination of options B–F.

B AMC-1000D AUTO PURGE CONTROLLER

Control the AMC 1000D Auto Purge Valve (highly recommended). INCLUDES: Controller Housed in a NEMA Panel, Timers, and Air-actuated Purge Valve. Utility Requirements: Compressed air (3 cfm @ 85 PSI activated), and 120 volt @ 3 amps.

C OZONE SYSTEMS

Creates ozone and mixes it for sterilization of water. INCLUDES: Circulation Pump, Timer, Mazzei Injector, and Manifold. Utility Requirements: 120 volt @ 9 amps.

D PH CONTROL SYSTEM

Controls pH of the water with a peristaltic pump. INCLUDES: Controller with Inline Manifold with Probe and Injector, Peristaltic Chemical Feed Pump with Flow Switch. Utility Requirements: 120 volt @ 3 amp.

E AUTO WATER DISCHARGE / CIRCULATION VALVE SYSTEM
Allow water to flow (24/7) back to the pit system reducing stagnant water issues. Utility Requirements: 120 volt @ 1 amp.

F SLUDGE TRAY

Dewatering sludge tray with lid; stainless steel riser; and 5 sludge bags (supplied as a loose item).

UNIVERSAL CLARIFIER CONFIGURATION CHECK LIST

DESCRIPTION	ITEM #		SPECIFICATIONS
OPTION 1 SELECT TANK SIZE - SELECT ONE	CLT-300	CLT-600	
Cone-bottom tank , cradle, and lid	1-300 1.103-434.0	1-600 1.103-435.0	1-300: OWS up to 10 GPM, CoAg up to 8 GPM 1-600: OWS up to 30 GPM, CoAg up to 16 GPM
OPTION 2 SELECT OIL COALESCING / SEPARATOR CONES			
CLT-300 - Additional 4 cones (ref above 3B-300)	4A-300	4B-600	CLT-300 also select 3B-300
CLT-600 - Additional 8 cones (ref above 3B-600)			CLT-600 also select 4B-600
SELECT OIL SKIMMER - IF APPLICABLE (FOR REMOVAL OF FREE-FLOATING OILS)			
Belt-Mop skimmer w/ oil decanter	3A-300	3A-600	120 volt @ 9 amps (separate 120V circuit required)
Funnel skimmer, 2 cones, oil decanter	3B-300	3B-600	
OPTION 3 SELECT INTERNAL SETTLING MANIFOLD - FOR SOLIDS SETTLING, AS WELL AS SETTLING OF FLOCCULATED MATTER			
Internal tank-in-tank design	2-300	2-600	
OPTION 4 SELECT BIO-DIGESTER			
Bio-digester package (CLT-600 only)	—	5-600	
SELECT EXTERNAL OPTIONS			
Mounting shield - for installing electrical control panels	7A-300	7A-600	
AMC-1000D Auto-purge system installed. Compressed air required	7B-300	7B-600	120 volt, @ 3 amps, 4 cfm @ 85 psi
UV Ozone system with circulation pump and timer	7C-300	7C-600	120 volt, 9 amps
pH Controller system	7D-300	7D-600	120 volt, 3 amps
Integrated Chemical Coagulation /Flocculation system	7E-300	7E-600	120 volt, 10 amps
MetalR+ Chemical injection added to above CoAg sys	7F-300	7F-600	
Auto-water Discharge / Circulation valve (not recommended with CoAg)	7G-300	7G-600	120 volt, 3 Amps
Sludge Tray / dewatering tray with lid, stainless-steel riser, 5 bags		8.906-478.0	



PEAK MODULARITY

- The Universal Clarifier is the utmost in modular systems for wash water treatment. A Water Maze Applications Engineer will help you determine from a menu of options the ideal fit for the unique properties of your wastewater and its intended destination whether it be to recycle, evaporate, discharge or haul-away.
- Coalescing cone options fit well for oily wash water, tank-in-tank options are ideal when solids removal is needed, while the bio-digester options are reserved for the larger 600-gallon base unit and are the best way to treat dissolved organic chemicals in the wastewater.

CUSTOMIZE AND ACCESSORIZE

- Accessories enhance the effectiveness of Water Maze Treatment Systems. Water Maze offers a broad selection of add-ons, accessories, parts, and consumables that support the performance of your water treatment systems.

DETERGENTS, MEDIA AND CONSUMABLES

- Water Maze offers a variety of additives, defoamers and detergents that are compatible with your pressure washer equipment and enhance the effectiveness of pressure washer and water treatment systems. We have a line of quick-release detergents available in 5 and 55 gallons. Filter media such as sand, gravel, and clay, which help provide separation of contaminants in water filtration equipment. We also offer bio-pucks and biostax products for our bioremediation systems, that are designed to alleviate odor in collection pits.

TECHNICAL DATA

MODEL	PART NO.	DESCRIPTION	CAPACITY (GAL)	FLOW GPM	EST. SHIP WEIGHT (LBS.)
CLT-300	1.103-434.0	Modular Clarifier System Base Unit with Stand	300	1 – 15	592
CLT-600	1.103-435.0	Modular Clarifier System Base Unit with Stand	600	1 – 30	1,000

Dimensions (approximate):

CLT-300 Physical: 45" x 45" x 86" Shipping: 57" x 40" x 87"
 CLT-600 Physical: 55" x 55" x 104" Shipping: 65" x 72" x 100"

Estimated product tare weight: 560 lbs.
 Estimated product tare weight: 835 lbs.

CONFIGURATION OPTIONS

PART NO.	BASE UNIT -300	BASE UNIT -600	COALESCING CONES	TANK IN TANK	BIO-DIGESTERS	DESCRIPTION
2	■	■		■		CoAg Mixing Chamber (inside tank)
3A	■	■	■			Belt Mop Skimmer, 120 V/6 Amp, with Oil Decanter Container (CLT-600, -300, or -150)
3B	■	■	■			Coalescing cones (2) with Funnel Oil Skimming, with Oil Decanter Container
4A	■	■	■			Additional Coalescing Cones (CLT-300: up to a total of 6; CLT-600: up to a total of 10)
5		■			■	Biomedica Kit (EoFill)
6	■	■	■			Rotating self-cleaning screen mounted vertically inside CLT tank
7A	■	■	■	■	■	Mounting Shield ‡
7B	■	■	■	■	■	AMC-1000D Auto-purge System (4CFM @ 85 PSI), 120 V/2 Amps **
7C	■	■	■	■	■	UV Ozone System with circulation pump and timer, 120 V/9 Amps **
7D	■	■	■	■	■	pH (only) Controller with one peristaltic pump electrically interfaced with the infeed pump / sump pump circuit ‡
7E	■	■		■		Integrated Compact CoAg (in lieu of stand-alone Compact CoAg module) ‡
7F	■	■		■		MetalR+ Chemical Injection Package (option to be used only with CoAg modules) ‡
7G	■	■	■	■	■	Auto-water Discharge/Circulation Valve System, 120 V/2 Amps **
8.906-478.0	■	■	■	■	■	Sludge Tub with Lid
8.712-417.0		■			■	Diffuser Stone, fine pore, 2"x2"x6.5"
8.707-435.0		■			■	Biomedica Bag
8.706-676.0		■			■	EoFill (BioMedia) – 8 lbs / bag (sold by the pound)

‡ Factory Install Only. * Requires Rain Guard and Bracket option. NOTE: Sump pumps sold separately. Extended lead times apply to all orders placed through our Specials Department.