



633 N Helena St, Spokane, WA 99202
 509.535.1555 | info@northstardirect.com
 1210 N Oregon Ave, Pasco, WA 99301
 509.547.2323 | info@northstarhotsy.com



FIBERGLASS PIT SYSTEMS

IN-GROUND PRE-TREATMENT SYSTEMS

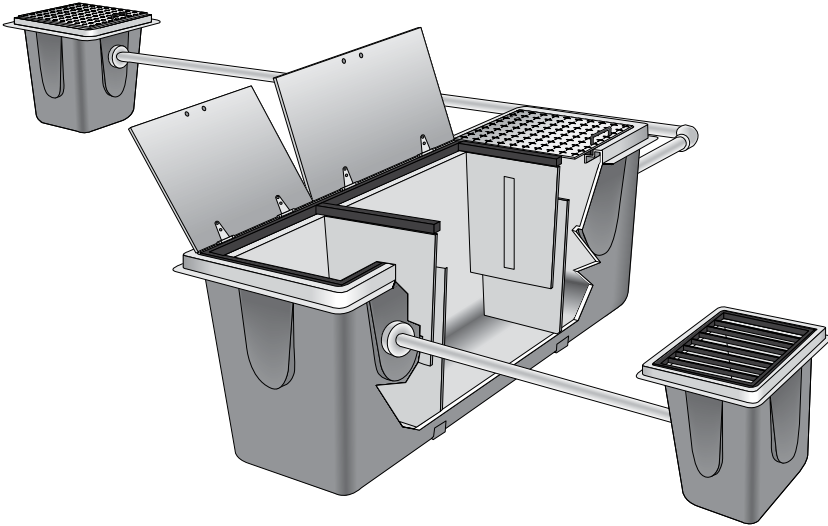

IN-GROUND FIBERGLASS PIT SYSTEMS

Water Maze offers in-ground fiberglass pits, which are easy to install. As compared to poured-in-place concrete pits that may eventually crack and allow water to leach into the ground, our fiberglass pits immersed into concrete can provide double containment. We offer three sizes of pits. The In-ground Separator (IGS) is uniquely designed with two sets of standing weirs that force solids to the bottom of the pit. The Fiberglass Pits are ideal pre-treatment of heavy settable solids prior to entering in the in-ground collection sump, as well as providing a water collection sump, and submersible pump lift station.

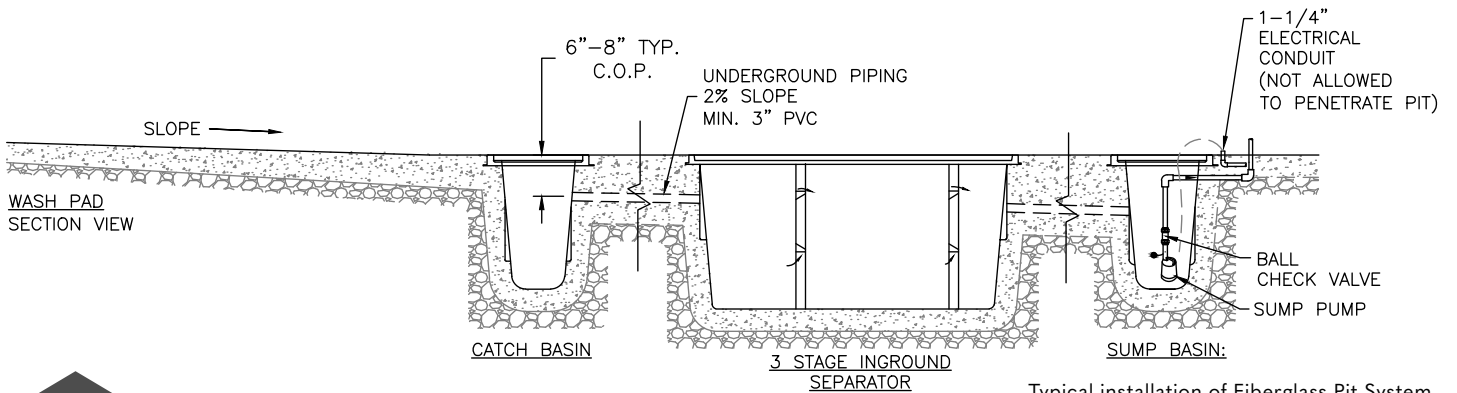

Typical installation of Fiberglass Pit System



CONTAINMENT IN-GROUND SEPARATORS

Below ground pre-treatment of wash water

Reinforced, pre-fabricated fiberglass

Easier and less expensive to install concrete

Chemically resistant fiberglass inhibits the growth of bacteria

Footprint:
 Catch Basin: 45 x 45 x 58
 Collection Pit: 120 x 46 x 55
 Sump Pit: 34 x 34 x 39



COALESCING SURFACE AREA

■ Optional coalescing packs equaling 1,700 square feet of oleophilic material can be placed inside the collection pit. Then coalescing packs will remove the free oils down to 20 micron from the wastewater stream.

CLEARING THE MUCK

■ Incorporate an In-ground Separator Fiberglass Pit System to properly treat pressure washer wastewater and muck generated from the cleaning of machinery and equipment, separating free oil and dirt from the water.

CUSTOMIZE AND ACCESSORIZE

■ Accessories enhance the effectiveness of Water Maze Treatment Systems. Water Maze offers a broad selection of add-ons, accessories, parts, and consumables that support the performance of your water treatment systems.

DETERGENTS, MEDIA AND CONSUMABLES

■ Water Maze offers a variety of additives, defoamers and detergents that are compatible with your pressure washer equipment and enhance the effectiveness of pressure washer and water treatment systems. We have a line of quick-release detergents available in 5 and 55 gallons. Filter media such as sand, gravel, and clay, which help provide separation of contaminants in water filtration equipment. We also offer bio-pucks and biostax products for our bioremediation systems, that are designed to alleviate odor in collection pits.

TECHNICAL DATA

MODEL	PART NO.	DESCRIPTION	CAPACITY (GAL)	FLOW GPM	MATERIAL	INSIDE DIMENSIONS (INCHES)	EST. SHIP WEIGHT (LBS.)
Collection Pit	8.903-657.0	In-ground Oil Separator Pit	600	up to 60	Fiberglass	108 x 36 x 60	180
Sump / Catch Pit	8.709-333.0	In-ground Catch Basin	159	—	Fiberglass	36 x 36 x 54	550
Sump / Catch Pit	8.709-334.0	In-ground Sump Pit	47	—	Fiberglass	24 x 24 x 36	110

Dimensions (approximate):

Collection Pit	Physical: 120" x 46" x 55"	Shipping: 125" x 52" x 66"	Estimated product tare weight: 302 lbs.
Catch Basin	Physical: 45" x 45" x 58"	Shipping: 53" x 47" x 65"	Estimated product tare weight: 130 lbs.
Sump Pit	Physical: 34" x 34" x 39"	Shipping: 39" x 42" x 42"	Estimated product tare weight: 75 lbs.

OPTIONAL ACCESSORIES

PART NO.	DESCRIPTION
Collection Pit Only	
8.903-674.0	Cover, Hinged Aluminum, Diamond Tread Plate with Steel Tube Frame, 3' x 9'
8.903-673.0	Coalescing Grid Packs, 58 Plates, 1,700 sq ft Surface Area
8.712-023.0	Wood Brace Kit (bracing to reinforce fiberglass while pouring concrete, required for installation of Collection Pit #8.903-657.0)
Catch Basin Only	
8.903-678.0	Cover, Aluminum Diamond Tread Plate, 3' x 3'
8.903-677.0	Grating*, Hot Rolled Steel, 1/2" x 2" Flatbar, 1.5' x 3' (includes 2 grates)
Sump Pit Only	
8.903-675.0	Cover, Aluminum Diamond Tread Plate with Steel Tube Frame, 2' x 2'
8.903-676.0	Grating*, Hot Rolled Steel 1/2" x 2" Flatbar, 2' x 2'

*Gratings meet H-20 truck load rating. Note: Sump pumps are sold separately.